



## RF TEST REPORT

**Certificate No.** : TBC-C-202601-0040-3  
**Report No.** : TBR-C-202601-0040-555  
**Applicant** : Heltec Automation Technology Co., Ltd  
**Equipment Under Test (EUT)**  
**EUT Name** : WiFi LoRa 32  
**Model No.** : HTIT-WBR2H  
HTIT-WB32LAF, HTIT-WBR2N, HTIT-WBR8H, HTIT-WBR8N,  
HTIT-WBR8G, HTIT-WBN8G, HTIT-WBR2G, HTIT-WB32A,  
**Series Model No.** : HTIT-WB32B, HTIT-WB32C, HTIT-WB32S, HTIT-WB32E1,  
HTIT-WB32E2, HTIT-WB32E3, HTIT-WB32E4, HTIT-WBNRT1,  
HTIT-WBNRT2  
**Brand Name** : Heltec Automation  
**Receipt Date** : 2026-04-09  
**Test Date** : 2026-04-09 to 2026-05-19  
**Issue Date** : 2026-05-20  
**Standards** : ETSI EN 300 220-1 V3.1.1:2017  
ETSI EN 300 220-2 V3.2.1:2018  
**Conclusions** : **PASS**

In the configuration tested, the EUT complied with the standards specified above. The EUT technically complies with the Council Directive 2014/53/EU relating to radio equipment.

**Tested By** : Lily Zhang  
**Reviewed By** : Wade W  
**Approved By** : Ivan Su



This report details the results of the testing carried out on one sample. The results contained in this test report do not relate to other samples of the same product. The manufacturer should ensure that all products in series production are in conformity with the product sample detailed in the report.

TB-RF-073-3.1

**TABLE OF CONTENTS**

**1 GENERAL INFORMATION ..... 5**

1.1 Client Information ..... 5

1.2 General Description of EUT (Equipment Under Test) ..... 5

1.3 Block Diagram Showing the Configuration of System Tested ..... 6

1.4 Description of Support Units ..... 6

1.5 Description of Operating Mode ..... 6

1.6 Measurement Uncertainty ..... 8

1.7 Test Facility ..... 8

**2 TEST RESULTS SUMMARY ..... 9**

**3 TEST SOFTWARE ..... 9**

**4 TEST EQUIPMENT AND TEST SITE ..... 10**

**5 OPERATING FREQUENCY ..... 12**

5.1 Test Standard and Limit ..... 12

5.2 Test Setup ..... 12

5.3 Test Procedure ..... 12

5.4 Deviation From Test Standard ..... 12

5.5 Test Data ..... 12

**6 UNWANTED EMISSIONS IN THE SPURIOUS DOMAIN ..... 13**

6.1 Test Standard and Limit ..... 13

6.2 Test Setup ..... 13

6.3 Test Procedure ..... 14

6.4 Deviation From Test Standard ..... 14

6.5 Test Data ..... 14

**7 TX EFFECTIVE RADIATED POWER ..... 15**

7.1 Test Standard and Limit ..... 15

7.2 Test Setup ..... 15

7.3 Test Procedure ..... 16

Conducted Measurement ..... 16

7.4 Deviation From Test Standard ..... 16

7.5 Test Data ..... 16

**8 DUTY CYCLE ..... 17**

8.1 Test Standard and Limit ..... 17

8.2 Test Setup ..... 17

8.3 Test Procedure ..... 17

8.4 Deviation From Test Standard ..... 18

8.5 Test Data ..... 18

**9 TX OCCUPIED BANDWIDTH ..... 19**

9.1 Test Standard and Limit ..... 19

9.2 Test Setup ..... 19

9.3 Test Procedure ..... 20

9.4 Deviation From Test Standard ..... 20

9.5 Test Data ..... 20

**10 TX OUT OF BAND EMISSIONS ..... 21**

10.1 Test Standard and Limit ..... 21

10.2 Test Setup ..... 22

10.3 Test Procedure ..... 22

10.4 Deviation From Test Standard ..... 23

10.5 Test Data ..... 23



<b>11</b>	<b>TX TRANSIENT</b> .....	<b>24</b>
	11.1 Test Standard and Limit .....	24
	11.2 Test Setup.....	24
	11.3 Test Procedure.....	24
	11.4 Deviation From Test Standard.....	24
	11.5 Test Data.....	24
<b>12</b>	<b>TX ADJACENT CHANNEL POWER</b> .....	<b>25</b>
	12.1 Test Standard and Limit .....	25
	12.2 Test Setup.....	25
	12.3 Test Procedure.....	25
	12.4 Deviation From Test Standard.....	26
	12.5 Test Data.....	26
<b>13</b>	<b>TX BEHAVIOUR UNDER LOW VOLTAGE CONDITIONS</b> .....	<b>27</b>
	13.1 Test Standard and Limit .....	27
	13.2 Test Setup.....	27
	13.3 Test Procedure.....	27
	13.4 Deviation From Test Standard.....	27
	13.5 Test Data.....	27
<b>14</b>	<b>BLOCKING</b> .....	<b>28</b>
	14.1 Test Standard and Limit .....	28
	14.2 Test Setup.....	28
	14.3 Test Procedure.....	29
	14.4 Deviation From Test Standard.....	29
	14.5 Test Data.....	29
<b>15</b>	<b>PHOTOGRAPHS--TEST SETUP</b> .....	<b>30</b>
	<b>ATTACHMENT A--UNWANTED EMISSIONS IN THE SPURIOUS DOMAIN</b> .....	<b>31</b>
	<b>ATTACHMENT B--TX EFFECTIVE RADIATED POWER</b> .....	<b>56</b>
	<b>ATTACHMENT C--DUTY CYCLE</b> .....	<b>57</b>
	<b>ATTACHMENT D--TX OCCUPIED BANDWIDTH</b> .....	<b>59</b>
	<b>ATTACHMENT E--TX OUT OF BAND EMISSIONS</b> .....	<b>60</b>
	<b>ATTACHMENT F--TRANSIENT POWER</b> .....	<b>63</b>
	<b>ATTACHMENT G--BLOCKING</b> .....	<b>72</b>





# 1 General Information

## 1.1 Client Information

<b>Applicant</b>	:	Heltec Automation Technology Co., Ltd
<b>Address</b>	:	1f, No. 54, 56, 58, Zirui North Street, Gaoxin District, Chengdu, China
<b>Manufacturer</b>	:	Heltec Automation Technology Co., Ltd
<b>Address</b>	:	1f, No. 54, 56, 58, Zirui North Street, Gaoxin District, Chengdu, China

## 1.2 General Description of EUT (Equipment Under Test)

<b>EUT Name</b>	:	WiFi LoRa 32	
<b>Model No.</b>	:	HTIT-WBR2H, HTIT-WB32LAF, HTIT-WBR2N, HTIT-WBR8H, HTIT-WBR8N, HTIT-WBR8G, HTIT-WBN8G, HTIT-WBR2G, HTIT-WB32A, HTIT-WB32B, HTIT-WB32C, HTIT-WB32S, HTIT-WB32E1, HTIT-WB32E2, HTIT-WB32E3, HTIT-WB32E4, HTIT-WBNRT1, HTIT-WBNRT2	
<b>Model Difference</b>	:	All these models are identical in the same PCB layout and electrical circuit, only difference is model name.	
<b>Product Description</b>	:	Operation Frequency:	LoRa: 863MHz~870MHz
	:	Number of Channel:	see note (2)
	:	Antenna Type:	2.39dBi Spring Antenna
	:	Modulation Type:	FSK
<b>Power Rating</b>	:	INPUT: DC 5.0V	
<b>Software Version</b>	:	N/A	
<b>Hardware Version</b>	:	N/A	
<b>Remark:</b> The antenna gain provided by the applicant, the verified for the RF conduction test provided by TOBY test lab. The above antenna information is declared by manufacturer and for more detailed features description, please refer to the manufacturer's specifications, the laboratory shall not be held responsible.			

**Note:**

- (1) For a more detailed features description, please refer to the manufacturer's specifications or the User's Manual.
- (2) Channel List:

Frequency (MHz)	Frequency (MHz)	Frequency (MHz)	Frequency (MHz)	Frequency (MHz)
863.1	864.5	865.9	867.3	868.7
863.3	864.7	866.1	867.5	868.9
863.5	864.9	866.3	867.7	869.1
863.7	865.1	<b>866.5</b>	867.9	869.3
863.9	865.3	866.7	868.1	869.5
864.1	865.5	866.9	868.3	869.7
864.3	865.7	867.1	868.5	<b>869.9</b>

- (3) Antenna information is provided by the applicant.



1.3 Block Diagram Showing the Configuration of System Tested

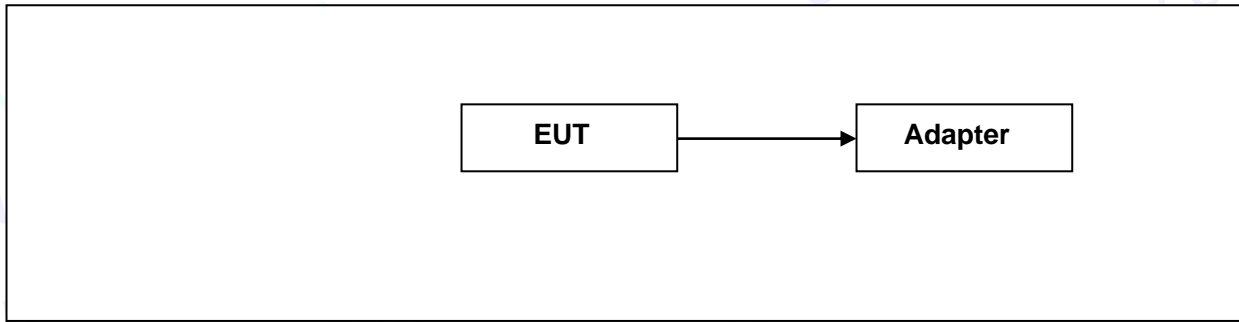

1.4 Description of Support Units

The EUT has been test as an independent unit.

1.5 Description of Operating Mode

To investigate the maximum EMI emission characteristics generated from EUT, the test system was pre-scanning tested based on the consideration of following EUT operation mode or test configuration mode which possible have effect on EMI emission level. Each of these EUT operation mode(s) or test configuration mode(s) mentioned above was evaluated respectively.

Test Mode: Continuously transmitting		
	Frequency (MHz)	Test Frequency (MHz)
K	863 MHz to 865 MHz	863.1
L	865 MHz to 868 MHz	866.5
Q	869.7 MHz to 870.0 MHz	869.9

	Normal Test Conditions	Extreme Test Conditions
Temperature	15°C~35°C	-20°C~70°C
Humidity	20%~75%	N/A
Supply Voltage	DC 5V	DC 3.0V~DC 5.5V

Note :

- (1) For tests at extreme temperatures, measurements shall be made in accordance with the procedures specified in clause 4.3.4.1.2(EN 300 220-1), at the upper and lower temperatures of the range as follows:

General	-25°C to +55°C
Portable	-10°C to +55°C
Normal indoor use	+5°C to +35°C
Automotive	-40°C to +125°C



**(2) Mains voltage:**

The extreme test voltage for equipment to be connected to an AC mains source shall be the nominal mains voltage  $\pm 10\%$ .

**Regulated lead-acid or gel-cell type batteries:**

When the radio equipment is intended for operation from the usual type of regulated lead-acid battery power sources, the extreme test voltages shall be 1,3 and 0,9 multiplied by the nominal voltage of the battery (6 V, 12 V, etc.).

For float charge applications using "gel-cell" type batteries, the extreme test voltages shall be 1,15 and 0,85 multiplied by the nominal voltage of the declared battery voltage.

**Power sources using other types of batteries:**

The lower extreme test voltages for equipment with power sources using the following types of battery shall be:

- For the Leclanché or lithium type battery: 0,85 times the nominal voltage of the battery;
- For the nickel-cadmium type of battery: 0,9 times the nominal voltage of the battery. In both cases, the upper extreme test voltage shall be 1,15 times the nominal voltage of the battery.
- For other types of batteries, the lower extreme test voltage for the discharged condition shall be declared by the equipment provider.

The nominal voltage is considered to be the upper extreme test voltage in this case.



### 1.6 Measurement Uncertainty

The reported uncertainty of measurement  $y \pm U$ , where expanded uncertainty  $U$  is based on a standard uncertainty multiplied by a coverage factor of  $k=2$ , providing a level of confidence of approximately 95 %.

Test Item	Expanded Uncertainty ( $U_{Lab}$ )
RF Power-Conducted	$\pm 0.95$ dB
Radiated Emission (30MHz to 1000 MHz)	$\pm 4.40$ dB
Radiated Emission (Above 1000MHz)	$\pm 4.20$ dB
Temperature	$\pm 0.6$ °C
Humidity	$\pm 4$ %
ERP (Radiated)	$\pm 3.84$ dB
Conducted Spurious Emission	$\pm 2.72$ dB
Frequency Error	$\pm 52.45$ Hz
Occupied Bandwidth	$\pm 3.8$ %
Power Density	$\pm 0.92$ dB

### 1.7 Test Facility

The testing report were performed by the Shenzhen Toby Technology Co., Ltd., in their facilities located at 1/F., Building 6, Rundongsheng Industrial Zone, Longzhu, Xixiang, Bao'an District, Shenzhen, Guangdong, China. At the time of testing, the following bodies accredited the Laboratory:

**CNAS (L5813)**

The Laboratory has been accredited by CNAS to ISO/IEC 17025: 2017 General Requirements for the Competence of Testing and Calibration Laboratories for the competence in the field of testing. And the Registration No.: CNAS L5813.

**A2LA Certificate No.: 4750.01**

The laboratory has been accredited by American Association for Laboratory Accreditation(A2LA) to ISO/IEC 17025: 2017 General Requirements for the Competence of Testing and Calibration Laboratories for the technical competence in the field of Electrical Testing. And the A2LA Certificate No.: 4750.01.FCC Accredited Test Site Number: 854351. Designation Number: CN1223.

**IC Registration No.: (11950A)**

The Laboratory has been registered by Certification and Engineering Bureau of Industry Canada for radio equipment testing. The site registration: Site# 11950A. CAB identifier: CN0056.



## 2 Test Results Summary

Harmonised Standards EN 300 220-2					
Requirement			Requirement Conditionality		Result
No	Description	Reference: Clause No	U/C	Condition	
1	Operating frequency	4.2.1	U	-	PASS
2	Unwanted emissions in the spurious domain	4.2.2	U	-	PASS
3	TX effective radiated power	4.3.1	U	-	PASS
4	TX Maximum e.r.p. spectral density	4.3.2	C	Applies to EUT using annex B bands I, L. Applies to EUT using DSSS or wideband techniques other than FHSS modulation, using annex C band X.	N/A
5	TX Duty cycle	4.3.3	C	Not applicable to EUT with polite spectrum access where permitted in annex B, table B.1 or annex C, table C.1 or any NRI.	PASS
6	TX Occupied bandwidth	4.3.4	U	-	PASS
7	TX out of band emissions	4.3.5	C	Applies to EUT with OCW > 25 kHz.	PASS
8	TX Transient Power	4.3.6	U	-	PASS
9	TX Adjacent channel power	4.3.7	C	Applies to EUT with OCW ≤ 25 kHz.	N/A
10	TX behaviour under low voltage conditions	4.3.8	C	Applies to battery powered EUT.	N/A
11	TX Adaptive power control	4.3.9	C	Applies to EUT with adaptive power control using annex C band AA.	N/A
12	TX FHSS	4.3.10	C	Applies to FHSS EUT.	N/A
13	TX Short term behaviour	4.3.11	C	Applies to EUT using annex C bands Y, Z, AA, AB, AC, AD.	N/A
14	RX sensitivity	4.4.1	C	Applies to EUT with polite spectrum access.	N/A
15	Clear channel assessment threshold	4.5.2	C	Applies to EUT with polite spectrum access.	N/A
16	Polite spectrum access timing parameters	4.5.3	C	Applies to EUT with polite spectrum access.	N/A
17	RX Blocking	4.4.2	U	-	PASS
18	Adaptive Frequency Agility	4.5.4	C	Applies to EUT with AFA.	N/A

**Note:**  
 (1) "N/A" indicates test is not applicable in this Test Report.  
 (2) "U/C": Indicates whether the requirement is unconditionally applicable (U) or is conditional upon the manufacturer's claimed functionality of the equipment (C).

## 3 Test Software

Test Item	Test Software	Manufacturer	Version No.
Radiation Emission	EZ-EMC	EZ	Ver.GARAD-3A1.1+
Radiation Emission	EZ-EMC	EZ	Ver.GARAD-3A1.1+
RF Conducted Measurement	MTS-8310	MWRFtest	V2.0.0.0
RF Test System	JS1120	Tonscend	V3.6.21



## 4 Test Equipment and Test Site

Test Site				
No.	Test Site	Manufacturer	Specification	Used
TB-EMCSR001	Shielding Chamber #1	YIHENG	7.5*4.0*3.0 (m)	X
TB-EMCSR002	Shielding Chamber #2	YIHENG	8.0*4.0*3.0 (m)	√
TB-EMCCA001	3m Anechoic Chamber #A	ETS	9.0*6.0*6.0 (m)	X
TB-EMCCB002	3m Anechoic Chamber #B	YIHENG	9.0*6.0*6.0 (m)	√

Radiation Emission Test (B Site)					
Equipment	Manufacturer	Model No.	Serial No.	Last Cal.	Cal. Due Date
Spectrum Analyzer	Agilent	N9020A	MY49100060	Aug. 27, 2025	Aug. 26, 2026
Spectrum Analyzer	Rohde & Schwarz	FSV40-N	102197	Jun. 16, 2025	Jun. 15, 2026
EMI Test Receiver	Rohde & Schwarz	ESU-8	100472/008	Jan. 30, 2026	Jan. 29, 2027
Bilog Antenna	SCHWARZBECK	VULB 9168	1225	Oct. 18, 2025	Oct. 17, 2027
Horn Antenna	SCHWARZBECK	BBHA 9120 D	2463	Jun. 14, 2024	Jun. 13, 2026
Horn Antenna	SCHWARZBECK	BBHA 9170	1118	Jan. 31, 2026	Jan. 30, 2028
Loop Antenna	SCHWARZBECK	FMZB 1519 B	1519B-059	Jun. 14, 2024	Jun. 13, 2026
HF Amplifier	Tonscend	TAP9E6343	AP21C806117	Aug. 27, 2025	Aug. 26, 2026
HF Amplifier	Tonscend	TAP051845	AP21C806141	Aug. 27, 2025	Aug. 26, 2026
HF Amplifier	Tonscend	TAP0184050	AP21C806129	Feb. 02, 2026	Feb. 01, 2027
Highpass Filter	CD	HPM-6.4/18G	---	N/A	N/A
Highpass Filter	CD	HPM-2.8/18G	---	N/A	N/A
Highpass Filter	XINBO	XBLBQ-HTA67(8-25G)	22052702-1	N/A	N/A
Antenna Conducted Emission					
Equipment	Manufacturer	Model No.	Serial No.	Last Cal.	Cal. Due Date
Spectrum Analyzer	Agilent	E4407B	MY45106456	Jun. 16, 2025	Jun. 15, 2026
Spectrum Analyzer	Rohde & Schwarz	FSV40-N	102197	Jun. 16, 2025	Jun. 15, 2026
MXA Signal Analyzer	KEYSIGHT	N9020B	MY60110172	Aug. 27, 2025	Aug. 26, 2026
MXA Signal Analyzer	Agilent	N9020A	MY47380425	Aug. 27, 2025	Aug. 26, 2026
Vector Signal Generator	Agilent	N5182A	MY50141294	Aug. 27, 2025	Aug. 26, 2026
Analog Signal Generator	Agilent	N5181A	MY48180463	Aug. 27, 2025	Aug. 26, 2026
Vector Signal Generator	KEYSIGHT	N5182B	MY59101429	Aug. 27, 2025	Aug. 26, 2026
Analog Signal Generator	KEYSIGHT	N5173B	MY61252685	Aug. 27, 2025	Aug. 26, 2026
RF Power Sensor	DARE!! Instruments	RadiPowerRPR3006W	17I00015SNO26	Aug. 27, 2025	Aug. 26, 2026
	DARE!! Instruments	RadiPowerRPR3006W	17I00015SNO29	Aug. 27, 2025	Aug. 26, 2026
	DARE!! Instruments	RadiPowerRPR3006W	17I00015SNO31	Aug. 27, 2025	Aug. 26, 2026
	DARE!! Instruments	RadiPowerRPR3006W	17I00015SNO33	N/A	N/A
RF Control Unit	Tonsced	JS0806-1	21C8060380	Aug. 27, 2025	Aug. 26, 2026
RF Control Unit	Tonsced	JS0806-2	21F8060439	N/A	N/A
Power Control Box	Tonsced	JS0806-4ADC	21C8060387	Aug. 27, 2025	Aug. 26, 2026



Wideband Radio Communication Tester	Rohde & Schwarz	CMW500	144382	Aug. 27, 2025	Aug. 26, 2026
Universal Radio Communication Tester	Rohde & Schwarz	CMW500	168796	Jan. 30, 2026	Jan. 29, 2027
Temperature and Humidity Chamber	ZhengHang	ZH-QTH-225D	ZH2107290	Jun. 16, 2025	Jun. 15, 2026



## 5 Operating frequency

### 5.1 Test Standard and Limit

#### 5.1.1 Test Standard

**ETSI EN 300 220-1 V3.1.1:2017 clause 5.1**  
**ETSI EN 300 220-2 V3.2.1:2018 clause 4.2.1**

#### 5.1.2 Test Limit

	Operational Frequency Band	Maximum effective radiated power, e.r.p.	Channel access and occupation rules (e.g. Duty cycle or LBT + AFA)	Maximum occupied bandwidth	Other usage restrictions	Band number from EC Decision 2017/1483/EU [2]
H	433,050 MHz to 434,790 MHz	10 mW	10 %	The whole band		44b, 45b
I	433,050 MHz to 434,790 MHz	1 mW e.r.p. -13 dBm/10 kHz power spectral density for bandwidth modulation larger than 250 kHz	No requirement	The whole band	Audio and video applications are excluded.	44a, 45a
J	434,040 MHz to 434,790 MHz	10 mW e.r.p.	No requirement	25kHz	Audio and video applications are excluded.	45c
K	863 MHz to 865 MHz	25 mW e.r.p.	≤0,1 % duty cycle or polite spectrum access	The whole band except for audio & video applications limited to 300 kHz		46a
L	865 MHz to 868 MHz	25 mW e.r.p.	≤1 % duty cycle or polite spectrum access	The whole band		47
M	868,000 MHz to 868,600 MHz	25 mW e.r.p.	≤1 % duty cycle or polite spectrum access	The whole band		48
N	868,700 MHz to 869,200 MHz	25 mW e.r.p.	≤0.1 % duty cycle or polite spectrum access	The whole sub-band		50
P	869,400 MHz to 869,650 MHz	500 mW e.r.p.	≤10 % duty cycle or polite spectrum access	The whole band		54
P	869,700 MHz to 870,000 MHz	5 mW e.r.p.	No requirement	The whole band	Audio and video applications are excluded.	56a
Q	869,700 MHz to 870,000 MHz	25 mW e.r.p.	≤0.1 % duty cycle or polite spectrum access	The whole band	Analogue audio applications are excluded. Analogue video applications are excluded.	56b

### 5.2 Test Setup

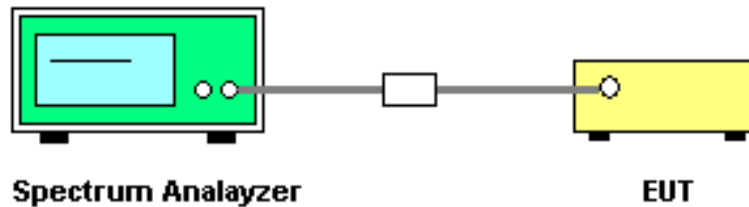

### 5.3 Test Procedure

Table 6: Information Recorded in the Test Report for Operating Frequency test

Value	Notes
Operational Frequency band or bands	Declared by the manufacturer
Nominal Operating Frequency or Frequencies	Declared by the manufacturer
Operating Channel width(s) - OCW	Declared by the manufacturer

### 5.4 Deviation From Test Standard

No deviation

### 5.5 Test Data

The operating frequency declared by the manufacturer accord with a standard.



## 6 Unwanted Emissions in The Spurious Domain

### 6.1 Test Standard and Limit

#### 6.1.1 Test Standard

ETSI EN 300 220-1 V3.1.1:2017 clause 5.9

ETSI EN 300 220-2 V3.2.1:2018 clause 4.2.2

#### 6.1.2 Test Limit

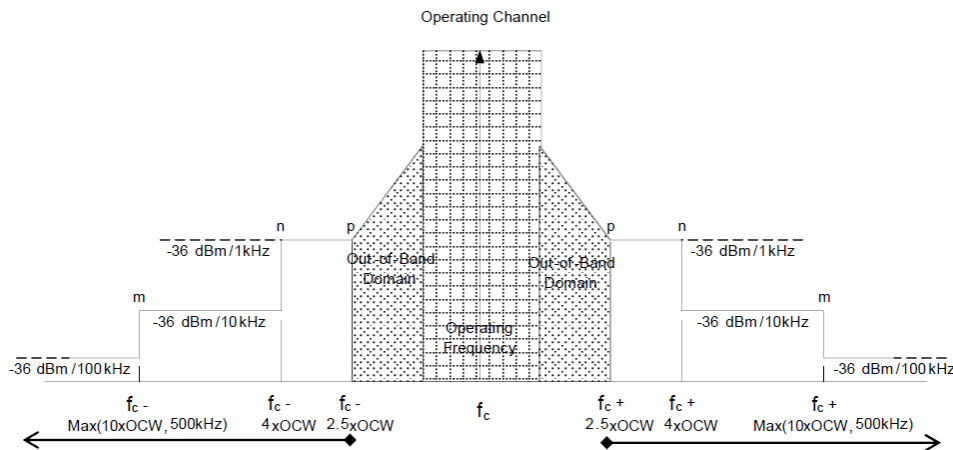

Figure 7: Spectrum Mask for Unwanted Emissions in the Spurious Domain with reference BW

Spurious emissions are unwanted emissions in the spurious domain at frequencies other than those of the Operating Channel and its Out Of Band Domain. The relevant spurious domain is shown in Figure 7.

The power of any unwanted emission in the spurious domain shall not exceed the values given in Table 19.

Table 19: Spurious domain emission limits

Frequency	47 MHz to 74 MHz 87,5 MHz to 118 MHz 174 MHz to 230 MHz 470 MHz to 790 MHz	Other frequencies below 1 000 MHz	Frequencies above 1 000 MHz
State			
TX mode	-54 dBm	-36 dBm	-30 dBm
RX and all other modes	-57 dBm	-57 dBm	-47 dBm

### 6.2 Test Setup

#### Below 1G

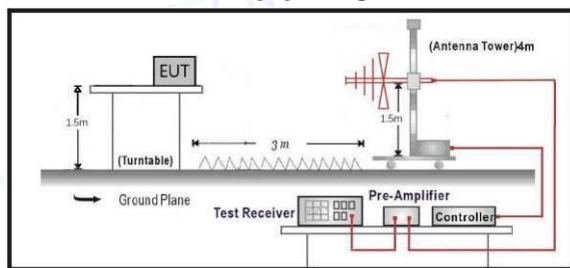

#### Above 1G

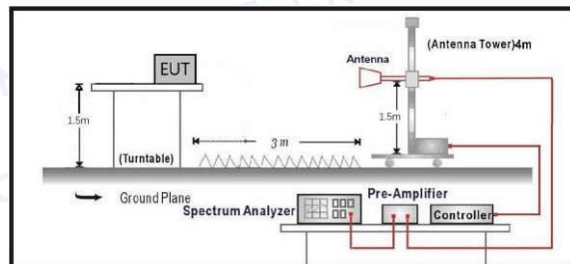

**6.3 Test Procedure**

A suitable test site shall be selected from those described in clause C.1. The EUT shall be connected to its normal operating antenna. The output of the test antenna shall be connected to a measuring receiver. The measurements described shall be performed using appropriate radiated measurement methods described in clause C.5.1 (or clause C.5.2) depending on the test site, followed by clause C.5.3. The operation of the EUT shall be started. For TX mode clause 5.9.3.1 applies. The measuring receiver shall be tuned over the frequency range shown in Table 22.

**Table 22: Spurious Radiations radiated Measurement Frequency Range**

Frequency Range	
25 MHz to 6 GHz	
NOTE:	The measurements need only to be performed over the frequency range 4 GHz to 6 GHz if emissions are detected within 10 dB of the specified limit between 1,5 GHz and 4 GHz.

At each frequency at which a spurious component is detected within the frequency range in Table 22, the spurious emission power level shall be established using the procedures described in clause C.5 and noted in the report.

The maximum signal level detected by the measuring receiver for vertical and horizontal polarization shall be noted.

The radiated measurements in clause C.5.1 (or clause C.5.2) followed by the substitution measurement defined in clause C.5.3 shall be performed with the frequency of the calibrated signal generator set to the frequency of the spurious component detected and, if necessary, the input attenuator setting of the measuring receiver adjusted in order to increase the sensitivity of the measuring receiver.

The measure of the effective radiated power of the spurious component is the larger of the two power levels at the input to the substitution antenna increased by the substitution antenna gain corrected by the cable loss (values in dB).

The power measured shall be recorded in the test report for each spurious component.

**6.4 Deviation From Test Standard**

No deviation

**6.5 Test Data**

Please refer to the Attachment A.



## 7 TX Effective Radiated Power

### 7.1 Test Standard and Limit

#### 7.1.1 Test Standard

**ETSI EN 300 220-1 V3.1.1:2017 clause 5.2**

**ETSI EN 300 220-2 V3.2.1:2018 clause 4.3.1**

#### 7.1.2 Test Limit

	Operational Frequency Band	Maximum effective radiated power, e.r.p.	Channel access and occupation rules (e.g. Duty cycle or LBT + AFA)	Maximum occupied bandwidth	Other usage restrictions	Band number from EC Decision 2017/1483/EU [2]
H	433,050 MHz to 434,790 MHz	10 mW	10 %	The whole band		44b, 45b
I	433,050 MHz to 434,790 MHz	1 mW e.r.p. -13 dBm/10 kHz power spectral density for bandwidth modulation larger than 250 kHz	No requirement	The whole band	Audio and video applications are excluded.	44a, 45a
J	434,040 MHz to 434,790 MHz	10 mW e.r.p.	No requirement	25kHz	Audio and video applications are excluded.	45c
K	863 MHz to 865 MHz	25 mW e.r.p.	≤0,1 % duty cycle or polite spectrum access	The whole band except for audio & video applications limited to 300 kHz		46a
L	865 MHz to 868 MHz	25 mW e.r.p.	≤1 % duty cycle or polite spectrum access	The whole band		47
M	868,000 MHz to 868,600 MHz	25 mW e.r.p.	≤1 % duty cycle or polite spectrum access	The whole band		48
N	868,700 MHz to 869,200 MHz	25 mW e.r.p.	≤0.1 % duty cycle or polite spectrum access	The whole sub-band		50
P	869,400 MHz to 869,650 MHz	500 mW e.r.p.	≤10 % duty cycle or polite spectrum access	The whole band		54
P	869,700 MHz to 870,000 MHz	5 mW e.r.p.	No requirement	The whole band	Audio and video applications are excluded.	56a
Q	869,700 MHz to 870,000 MHz	25 mW e.r.p.	≤0.1 % duty cycle or polite spectrum access	The whole band	Analogue audio applications are excluded. Analogue video applications are excluded.	56b

### 7.2 Test Setup

#### Conducted Measurement

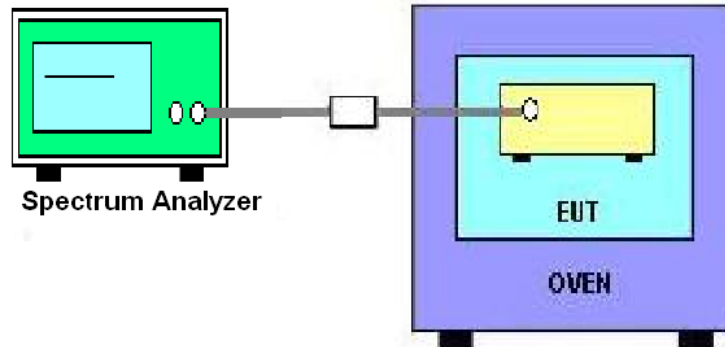

#### Radiated Measurement

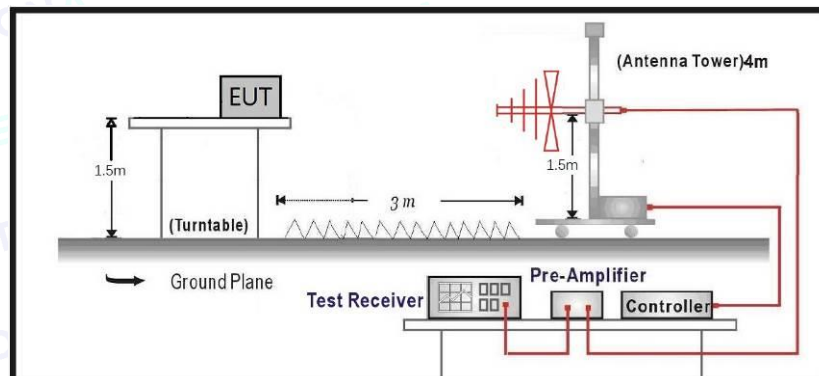

**7.3 Test Procedure**

**Conducted Measurement**

The transmitter shall be connected to a dummy load as described in clause 4.3.7 and the conducted power delivered shall be measured with a measurement receiver according to clause 4.3.10. In the case of non-constant envelope modulation, a peak detector shall be used. The maximum gain of the antenna to be used together with the equipment shall be declared by the manufacturer and this shall be recorded in the test report. Perp, the radiated power (e.r.p.) limit applies to the maximum measured conducted power ( $P_{conducted}$ ) value adjusted by the antenna gain (relative to a dipole) ( $P_{erp}=P_{conducted}+antenna\ gain$ ). The information shown in Table 7 shall be recorded in the test report.

**Table 7: Information Recorded in the Test Report for conducted Effective Radiated Power**

Value	Notes
Test environment	Normal operation or unmodulated carrier
Centre frequency	Nominal Operating Frequency
Measured Effective Radiated Power	maximum measured conducted power value adjusted by the antenna gain (relative to a dipole)
NOTE: In case of a dedicated antenna the antenna gain (in dB, i.e. relative to a dipole) is declared by the manufacturer.	

**Radiated Measurement**

A suitable test site shall be selected from those described in clause C.1 and the radiated power established using the procedures described in clause C.5.1 (or clause C.5.2) depending on the test site, followed by clause C.5.3. In the case of non-constant envelope modulation, a peak detector shall be used. The information shown in Table 8 shall be recorded in the test report.

**Table 8: Information Recorded in the Test Report for Effective Radiated Power**

Value	Notes
Test environment	Normal operation or unmodulated carrier
Centre frequency	Nominal Operating Frequency
Measure of Effective Radiated Power	Larger value from horizontal and vertical measurement equivalent radiated power, plus equipment antenna gain
NOTE: In case of a removable antenna the antenna gain (in dB, i.e. relative to a dipole) is declared by the manufacturer.	

**7.4 Deviation From Test Standard**

No deviation

**7.5 Test Data**

Please refer to the Attachment B.



## 8 Duty cycle

### 8.1 Test Standard and Limit

#### 8.1.1 Test Standard

**ETSI EN 300 220-1 V3.1.1:2017 clause 5.4**  
**ETSI EN 300 220-2 V3.2.1:2018 Annex B&C**

#### 8.1.2 Test Limit

	Operational Frequency Band	Maximum effective radiated power, e.r.p.	Channel access and occupation rules (e.g. Duty cycle or LBT + AFA)	Maximum occupied bandwidth	Other usage restrictions	Band number from EC Decision 2017/1483/EU [2]
H	433,050 MHz to 434,790 MHz	10 mW	10 %	The whole band		44b, 45b
I	433,050 MHz to 434,790 MHz	1 mW e.r.p. -13 dBm/10 kHz power spectral density for bandwidth modulation larger than 250 kHz	No requirement	The whole band	Audio and video applications are excluded.	44a, 45a
J	434,040 MHz to 434,790 MHz	10 mW e.r.p.	No requirement	25kHz	Audio and video applications are excluded.	45c
K	863 MHz to 865 MHz	25 mW e.r.p.	≤0,1 % duty cycle or polite spectrum access	The whole band except for audio & video applications limited to 300 kHz		46a
L	865 MHz to 868 MHz	25 mW e.r.p.	≤1 % duty cycle or polite spectrum access	The whole band		47
M	868,000 MHz to 868,600 MHz	25 mW e.r.p.	≤1 % duty cycle or polite spectrum access	The whole band		48
N	868,700 MHz to 869,200 MHz	25 mW e.r.p.	≤0,1 % duty cycle or polite spectrum access	The whole sub-band		50
P	869,400 MHz to 869,650 MHz	500 mW e.r.p.	≤10 % duty cycle or polite spectrum access	The whole band		54
P	869,700 MHz to 870,000 MHz	5 mW e.r.p.	No requirement	The whole band	Audio and video applications are excluded.	56a
Q	869,700 MHz to 870,000 MHz	25 mW e.r.p.	≤0,1 % duty cycle or polite spectrum access	The whole band	Analogue audio applications are excluded. Analogue video applications are excluded.	56b

### 8.2 Test Setup

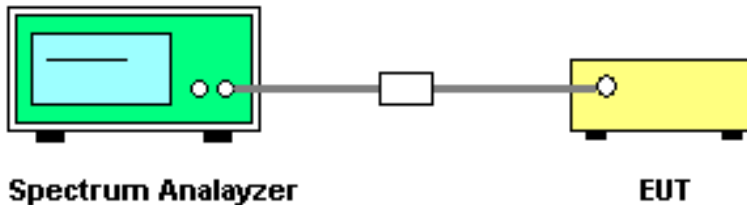

### 8.3 Test Procedure

The measurement setup is described in ETSI TS 103 060 [2], clause 5.

Table 10: Power Sensing Settings for short term behaviour measurement

Setting	Value	Notes
Sample rate	≥ 1 M samples/second	Sampling rate for at least 1 usecond resolution
Trigger		Trigger setting to capture leading edge of first transmission
P <sub>Threshold</sub>		Signal threshold
NOTE: The trigger setting shall be determined by the test laboratory. The threshold power level shall be agreed between the test laboratory and the manufacturer.		

The power sensing equipment as described in ETSI TS 103 060 [2], clause 5, shall be configured according to the settings in Table 10.

The EUT signal shall be measured with a power sensor and its levels adjusted according to the power envelope of the EUT transmissions.

#### Step 1:

The EUT shall be set to operate for not less than 10 transmissions.

The sampled power readings shall be saved.

NOTE 1: For low activity EUT it may be agreed with the test laboratory that a smaller number of transmissions may be accepted.

#### Step 2:

Using suitable analysis software the start time and stop time of each sequence of samples above P<sub>Threshold</sub> shall be obtained.



Between the saved start and stop times of each individual burst, the T<sub>On</sub> time shall be calculated. These T<sub>On</sub> values shall be saved.

Between the saved stop and start times of two subsequent bursts, the T<sub>Off</sub> time shall be calculated. These T<sub>Off</sub> values shall be saved.

NOTE 2: For low activity EUT, a note should be made if only a single transmission occurred.

**Step 3:**

Within the calculated T<sub>Off</sub> times, any interval less than T<sub>dis</sub> shall be discarded. The lowest value of T<sub>Off</sub> shall be noted.

The transmission duration is the time between two consecutive T<sub>Off</sub> intervals. The highest value calculated for transmission duration shall be noted.

NOTE 3: If only a single transmission occurred the duration is calculated from the samples directly and the T<sub>off</sub> time is the duration from the end of the transmission to the end of the sampling interval.

The information shown in Table 11 shall be recorded in the test report.

**Table 11: Information Recorded in the Test Report for DCT**

Value	Notes
Centre frequency	Nominal Operating Frequency
Measured sequence	T <sub>on cumulative</sub> and T <sub>off cumulative</sub> measured with T <sub>obs</sub> and F <sub>obs</sub>
DCT	DCT calculated with above measured parameters

**8.4 Deviation From Test Standard**

No deviation

**8.5 Test Data**

Please refer to the Attachment C.



## 9 TX Occupied Bandwidth

### 9.1 Test Standard and Limit

#### 9.1.1 Test Standard

**ETSI EN 300 220-1 V3.1.1:2017 clause 5.6**  
**ETSI EN 300 220-2 V3.2.1:2018 clause 4.3.4**

#### 9.1.2 Test Limit

The occupied bandwidth of the EUT according to ETSI EN 300 220-1 [1], clause 5.6.2 shall comply with the limits in annex B or any NRI for the chosen operational frequency band(s).

The Operating Channel shall be declared and shall reside entirely within the Operational Frequency Band. The Maximum Occupied Bandwidth at 99 % shall reside entirely within the Operating Channel defined by  $F_{low}$  and  $F_{high}$ .

Operational Frequency Band	Maximum effective radiated power, e.r.p.	Channel access and occupation rules (e.g. Duty cycle or LBT + AFA)	Maximum occupied bandwidth	Other usage restrictions	Band number from EC Decision 2017/1483/EU [2]
H 433,050 MHz to 434,790 MHz	10 mW 1 mW e.r.p. -13 dBm/10 kHz	10 %	The whole band		44b, 45b
I 433,050 MHz to 434,790 MHz		No requirement	The whole band	Audio and video applications are excluded.	44a, 45a
J 434,040 MHz to 434,790 MHz	10 mW e.r.p.	No requirement	25kHz	Audio and video applications are excluded.	45c
K 863 MHz to 865 MHz	25 mW e.r.p.	$\leq 0,1\%$ duty cycle or polite spectrum access	The whole band except for audio & video applications limited to 300 kHz		46a
L 865 MHz to 868 MHz	25 mW e.r.p.	$\leq 1\%$ duty cycle or polite spectrum access	The whole band		47
M 868,000 MHz to 868,600 MHz	25 mW e.r.p.	$\leq 1\%$ duty cycle or polite spectrum access	The whole band		48
N 868,700 MHz to 869,200 MHz	25 mW e.r.p.	$\leq 0,1\%$ duty cycle or polite spectrum access	The whole sub-band		50
P 869,400 MHz to 869,650 MHz	500 mW e.r.p.	$\leq 10\%$ duty cycle or polite spectrum access	The whole band		54
P 869,700 MHz to 870,000 MHz	5 mW e.r.p.	No requirement	The whole band	Audio and video applications are excluded.	56a
Q 869,700 MHz to 870,000 MHz	25 mW e.r.p.	$\leq 0,1\%$ duty cycle or polite spectrum access	The whole band	Analogue audio applications are excluded. Analogue video applications are excluded.	56b

### 9.2 Test Setup

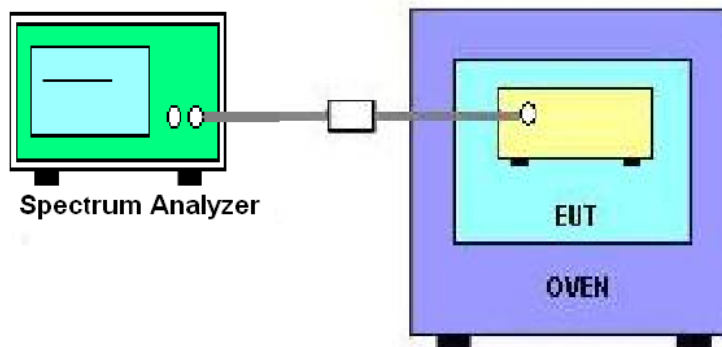

### 9.3 Test Procedure

The spectrum analyser shall be configured as appropriate for the parameters shown in Table 12.  
**Table 12: Test Parameters for Max Occupied Bandwidth Measurement**

Setting	Value	Notes
Centre frequency	The nominal Operating Frequency	The highest or lowest Operating Frequency as declared by the manufacturer
RBW	1 % to 3 % of OCW without being below 100 Hz	
VBW	3 x RBW	Nearest available analyser setting to 3 x RBW
Span	At least 2 x Operating Channel width	Span should be large enough to include all major components of the signal and its side bands
Detector Mode	RMS	
Trace	Max hold	

If the equipment is capable of producing an unmodulated carrier and the test in clause 5.7 is performed, then the OBW measurements need only be performed under normal test conditions. Any required results for Maximum OBW under extreme conditions are obtained by addition and subtraction of the upper and lower frequency error results to each bandwidth measurement obtained in this test.

**Step 1:**

Operation of the EUT shall be started, on the highest operating frequency as declared by the manufacturer, with the appropriate test signal.

The signal attenuation shall be adjusted to ensure that the signal power envelope is sufficiently above the noise floor of the analyser to avoid the noise signals on either side of the power envelope being included in the measurement.

**Step 2:**

When the trace is completed the peak value of the trace shall be located and the analyser marker placed on this peak.

**Step 3:**

The 99 % occupied bandwidth function of the spectrum analyser shall be used to measure the occupied bandwidth of the signal.

### 9.4 Deviation From Test Standard

No deviation

### 9.5 Test Data

Please refer to the Attachment D.



# 10 Tx Out of Band Emissions

## 10.1 Test Standard and Limit

### 10.1.1 Test Standard

**ETSI EN 300 220-1 V3.1.1:2017 clause 5.8**

**ETSI EN 300 220-2 V3.2.1:2018 clause 4.3.5**

### 10.1.2 Test Limit

The EUT emissions level in OOB domains for the Operating Channel and the Operational Frequency Band shall be less or equal to Table 15 spectrum mask.

Table 15: Emission limits in the Out Of Band domains

Domain	Frequency Range	RBW <sub>REF</sub>	Max power limit
OOB limits applicable to Operational Frequency Band (See Figure 6)	$f \leq f_{low\_OFB} - 400 \text{ kHz}$	10 kHz	-36 dBm
	$F_{low\_OFB} - 400 \text{ kHz} \leq f \leq f_{low\_OFB} - 200 \text{ kHz}$	1 kHz	-36 dBm
	$f_{low} - 200 \text{ kHz} \leq f < f_{low\_OFB}$	1 kHz	See Figure 6
	$f = f_{low\_OFB}$	1 kHz	0 dBm
	$f = f_{high\_OFB}$	1 kHz	0 dBm
	$F_{high\_OFB} < f \leq f_{high\_OFB} + 200 \text{ kHz}$	1 kHz	See Figure 6
	$F_{high\_OFB} + 200 \text{ kHz} \leq f \leq f_{high\_OFB} + 400 \text{ kHz}$	1 kHz	-36 dBm
	$F_{high\_OFB} + 400 \text{ kHz} \leq f$	10 kHz	-36 dBm
OOB limits applicable to Operating Channel (See Figure 5)	$f = f_c - 2.5 \times \text{OCW}$	1 kHz	-36 dBm
	$f_c - 2,5 \times \text{OCW} \leq f \leq f_c - 0,5 \times \text{OCW}$	1 kHz	See Figure 5
	$f = f_c - 0,5 \times \text{OCW}$	1 kHz	0 dBm
	$f = f_c + 0,5 \times \text{OCW}$	1 kHz	0 dBm
	$f_c + 0,5 \times \text{OCW} \leq f \leq f_c + 2,5 \times \text{OCW}$	1 kHz	See Figure 5
	$f = f_c + 2,5 \times \text{OCW}$	1 kHz	-36 dBm

NOTE:  $f$  is the measurement frequency.  
 $f_c$  is the Operating Frequency.  
 $F_{low\_OFB}$  is the lower edge of the Operational Frequency Band.  
 $F_{high\_OFB}$  is the upper edge of the Operational Frequency Band.  
 OCW is the operating channel bandwidth.

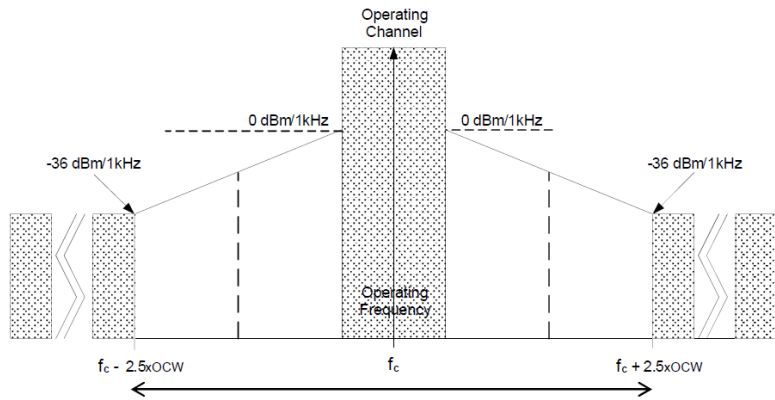

Figure 5: Out Of Band Domain for Operating Channel with reference BW

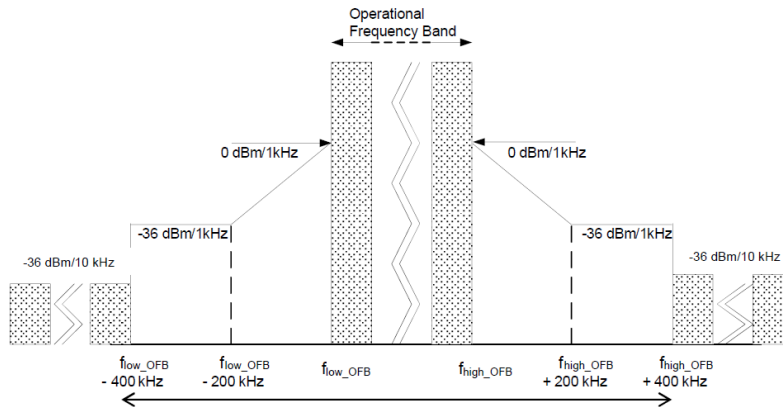
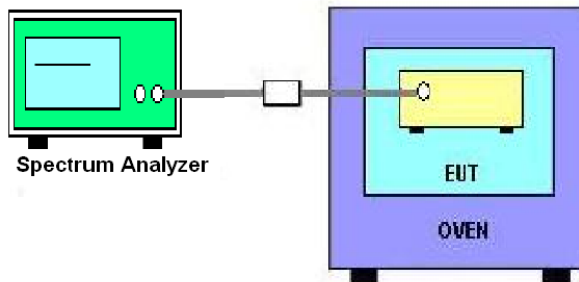

Figure 6: Out Of Band Domain for Operational Frequency Band with reference BW



### 10.2 Test Setup



### 10.3 Test Procedure

Table 16: Test Parameters for Out Of Band for Operating Channel Measurement

Spectrum Analyser Setting	Value	Notes
Centre frequency	Operating Frequency	
Span	6 x Operating Channel width	
RBW	1 kHz (see note)	Resolution bandwidth for Out Of Band domain measurements
Detector Function	RMS	
Trace Mode	Linear AVG	Applies only for EUT generating D-M2 test signal. An appropriate number of samples should be averaged to give a stable reading
	Max Hold	Applies only for EUT generating D-M2a or D-M3 test signal.
NOTE: If the value of RBW used is different from $RBW_{REF}$ in clause 5.8.2, use the bandwidth correction in clause 4.3.10.1.		

The test equipment shall be configured as appropriate for the parameters shown in Table 16.

**Step 1:**

Operation of the EUT shall be started, on the highest operating frequency as declared by the manufacturer, with the appropriate test signal.

The signal shape is recorded when stable and shall be below the spectrum mask Out Of Band for operating channel.

**Step 2:**

The test equipment shall be reconfigured as appropriate for the parameter shown in Table 17.

Table 17: Test Parameter Setting for Lower Out Of Band Measurement

Spectrum Analyser Setting	Value	Notes
Centre frequency	$f_{low}$	The lowest Operating Frequency in the band
Span	$2 \times (500 \text{ kHz} + f_{low} - f_{low\_OFB})$	Ensures that the left most mask specification remains within the span
NOTE: $f_{low\_OFB}$ is the lower edge of the Operational Frequency Band.		

Operation of the EUT is restarted, with the appropriate test signal, on the lowest operating frequency as declared by the manufacturer.

If the equipment is using only one operating Frequency in the operational Frequency Band, measurement shall be performed the nominal operating frequency.

The signal shape is recorded when stable; and shall be below the spectrum mask for operating channel and the spectrum mask for operational frequency band.

**Step 3:**

The test equipment shall be reconfigured as appropriate for the parameter shown in Table 18.

Table 18: Test Parameter Setting for upper Out Of Band Measurement

Spectrum Analyser Setting	Value	Notes
Centre frequency	$f_{high}$	the highest Operating Frequency in the band
Span	$2 \times (500 \text{ kHz} + f_{high\_OFB} - f_{high})$	Ensures that the rightmost mask specification remains within the span
NOTE: $f_{high\_OFB}$ is the higher edge of the operational frequency Band.		

Operation of the EUT is restarted, with the appropriate test signal, on the highest Operating Frequency as declared by the manufacturer.

If the equipment is using only one Operating Frequency in the Operational Frequency Band, measurement shall be performed at the nominal Operating Frequency

The signal shape is recorded when stable and shall be below the spectrum mask for Out Of Band emissions for operating channel and for operational Frequency Band.

**Step 4:**

For frequency agile devices, the measurement shall be repeated in each Operational Frequency Band.

**Step 5:**

Where required (see clause 5.8.3.1 condition 1), the measurements in step 1 to step 5 shall be repeated



---

under extreme test conditions.

#### 10.4 Deviation From Test Standard

No deviation

#### 10.5 Test Data

Please refer to the Attachment E.



# 11 TX Transient

## 11.1 Test Standard and Limit

### 11.1.1 Test Standard

**ETSI EN 300 220-1 V3.1.1:2017 clause 5.10**  
**ETSI EN 300 220-2 V3.2.1:2018 clause 4.3.6**

### 11.1.2 Test Limit

The transient power shall not exceed the values given in Table 23.

Table 23: Transmitter Transient Power limits

Absolute offset from centre frequency	RBW <sub>REF</sub>	Peak power limit applicable at measurement points
≤ 400 kHz	1 kHz	0 dBm
> 400 kHz	1 kHz	-27 dBm

## 11.2 Test Setup

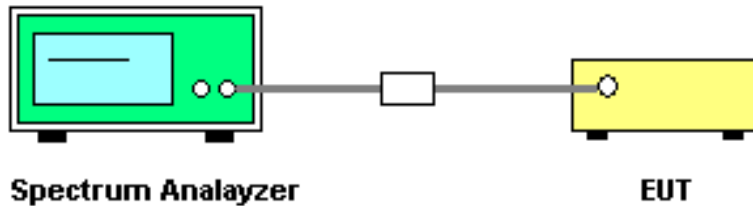

## 11.3 Test Procedure

The output of the EUT shall be connected to a spectrum analyser or equivalent measuring equipment. The measurement shall be undertaken in zero span mode. The analyser's centre frequency shall be set to an offset from the operating centre frequency. These offset values and their corresponding RBW configurations are listed in Table 24.

Table 24: RBW for Transient Measurement

Measurement points: offset from centre frequency	Analyser RBW	RBW <sub>REF</sub>
-0.5 x OCW - 3 kHz 0.5 x OCW + 3 kHz Not applicable for OCW < 25 kHz	1 kHz	1kHz
±12.5 kHz or ±OCW whichever is the greater	Max (RBW pattern 1, 3, 10 kHz) ≤ Offset frequency/6 (see note)	1 kHz
-0.5 x OCW - 400 kHz 0.5 x OCW + 400 kHz	100 kHz	1 kHz
-0.5 x OCW - 1 200 kHz 0.5 x OCW + 1 200 kHz	300 kHz	1 kHz
NOTE: Max (RBW pattern 1, 3, 10 kHz) means the maximum bandwidth that falls into the commonly implemented 1, 3, 10 kHz RBW filter bandwidth incremental pattern of spectrum analysers. EXAMPLE: If OCW is 25 kHz then the RBW value corresponding to one OCW offset frequency is 3 kHz. The rest of the analyser settings are listed in Table 25, and if OCW is 250 kHz then the RBW value corresponding to one OCW offset frequency is 30 kHz.		

Table 25: Parameters for Transient Measurement

Spectrum Analyser Setting	Value	Notes
VBW/RBW	10	At higher RBW values VBW may be clipped to its maximum value
Sweep time	500 ms	
RBW filter	Gaussian	
Trace Detector Function	RMS	
Trace Mode	Max hold	
Sweep points	501	
Measurement mode	Continuous sweep	
NOTE: The ratio between the number of sweep points and the sweep time shall be the same ratio as above if different number of sweep points is used.		

The used modulation shall be D-M3. The analyser shall be set to the settings of Table 25 and a measurement shall be started for each offset frequency. The EUT shall transmit at least five D-M3 test signal. The peak value shall be recorded and the measurement shall be repeated at each offset frequency mentioned in Table 24.

The recorded power values shall be converted to power values measured in RBWREF by the formula in clause 4.3.10.1.

## 11.4 Deviation From Test Standard

No deviation

## 11.5 Test Data

Please refer to the Attachment F.



## 12 TX Adjacent Channel Power

### 12.1 Test Standard and Limit

#### 12.1.1 Test Standard

**ETSI EN 300 220-1 V3.1.1:2017 clause 5.11**  
**ETSI EN 300 220-2 V3.2.1:2018 clause 4.3.7**

#### 12.1.2 Test Limit

Where the operating channel width is less than or equal to 25 kHz, the power in the adjacent channels shall not exceed the values given in Table 26.

Table 26: Adjacent channel power limits for transmitters with OCW ≤ 25 kHz

		Adjacent Channel power integrated over 0,7 x OCW	Alternate Adjacent Channel power integrated over 0,7 x OCW
OCW < 20 kHz	Normal test conditions	-20 dBm	-20 dBm
	Extreme test conditions	-15 dBm	-20 dBm
OCW ≥ 20 kHz	Normal test conditions	-37 dBm	-40 dBm
	Extreme test conditions	-32 dBm	-37 dBm

### 12.2 Test Setup

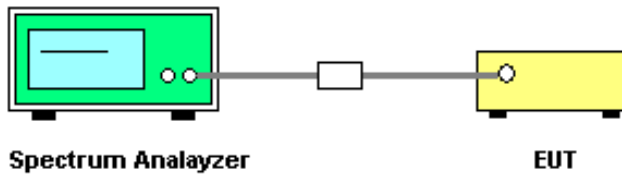

### 12.3 Test Procedure

The spectrum analyser shall be configured as appropriate for the parameters shown in Table 27.

Table 27: Test Parameters for Adjacent Channel Power

Setting	Value	Notes
Centre frequency	The nominal Operating Frequency	
RBW	100 Hz	
VBW	≥ 3 x RBW	
Span	At least 5 x Operating Channel width	Span should be large enough to include Adjacent and Alternate Adjacent Channel
Detector Mode	RMS	
Trace mode	Linear Averaging	Applies only for EUT generating D-M2 test signal An appropriate number of samples should be averaged to give a stable reading
	Max hold	Applies only for EUT generating D-M2a or D-M3 test signal
NOTE: The highest and lowest operating frequencies are declared by the manufacturer.		

#### Step 1:

Operation of the EUT shall be started, on the Operating Frequency as declared by the manufacturer. The modulation used shall be set according to Table 2.

The signal attenuation shall be adjusted to ensure that the signal power is not saturating the Spectrum analyser input port.

#### Step 2:

When the trace is completed, read the integrated power over a bandwidth of  $RBW_{REF}$  centered to an **offset from centre frequency** as specified in Table 28. The spectrum analyser's ACP personality or an integrating marker may be used. If the spectrum analyser's ACP personality is used any additional filtering over the integrating bandwidth shall be disabled.

Table 28: Offset and  $RBW_{REF}$  parameters

Measurement	Offset from centre frequency	$RBW_{REF}$
Adjacent channel	±OCW	0,7 x OCW
Alternate channel	±2 x OCW	0,7 x OCW

For extreme test conditions, if the measurement is performed under normal conditions only, for EUT generating D-M1 test signal measurement can be performed with the following frequency offsets from centre frequency:

- +OCW - |Negative Frequency Error| / -OCW + |Positive Frequency Error| apply for the adjacent channel
- +2xOCW - |Negative Frequency Error| / -2xOCW + |Positive Frequency Error| apply for the alternate adjacent channel.

Take the higher power value from the positive and negative offsets at both the adjacent channel and alternate channel results.

Lin Averaging on the trace is an advanced SA feature. It antilogs the results averages them than takes the log



again.

12.4 Deviation From Test Standard

No deviation

12.5 Test Data

No requirement for this test item



## 13 Tx Behaviour Under Low Voltage Conditions

### 13.1 Test Standard and Limit

#### 13.1.1 Test Standard

**ETSI EN 300 220-1 V3.1.1:2017 clause 5.12**  
**ETSI EN 300 220-2 V3.2.1:2018 clause 4.3.8**

#### 13.1.2 Test Limit

The equipment shall either:

- remain in the Operating Channel OC without exceeding any applicable limits (e.g. Duty Cycle); or
  - reduce its effective radiated power below the Spurious Emission limits without exceeding any applicable limits (e.g. Duty Cycle); or
  - shut down, (ceasing function);
- as the voltage falls below the manufacturers declared operating voltage.

### 13.2 Test Setup

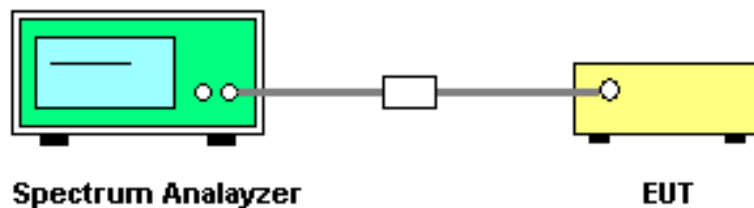

### 13.3 Test Procedure

#### Step 1:

Operation of the EUT shall be started, on Operating Frequency as declared by the manufacturer, with the appropriate test signal and with the EUT operating at nominal operating voltage. The centre frequency of the transmitted signal shall be measured and noted.

#### Step 2:

The operating voltage shall be reduced by appropriate steps until the voltage reaches zero. The centre frequency of the transmitted signal shall be measured and noted. Any abnormal behaviour shall be noted.

### 13.4 Deviation From Test Standard

No deviation

### 13.5 Test Data

N/A.



## 14 Blocking

### 14.1 Test Standard and Limit

#### 14.1.1 Test Standard

**ETSI EN 300 220-1 V3.1.1:2017 clause 5.18**

**ETSI EN 300 220-2 V3.2.1:2018 clause 4.4.2**

#### 14.1.2 Test Limit

**Table 40: Blocking level parameters for RX category 3**

Requirement	Limits
	Receiver category 3
Blocking at $\pm 2$ MHz from OC edge $f_{high}$ and $f_{low}$	$\geq -80$ dBm
Blocking at $\pm 10$ MHz from OC edge $f_{high}$ and $f_{low}$	$\geq -60$ dBm
Blocking at $\pm 5$ % of Centre Frequency or 15 MHz, whichever is the greater	$\geq -60$ dBm

**Table 41: Blocking level parameters for RX category 2**

Requirement	Limits
	Receiver category 2
Blocking at $\pm 2$ MHz from OC edge $f_{high}$ and $f_{low}$	$\geq -69$ dBm
Blocking at $\pm 10$ MHz from OC edge $f_{high}$ and $f_{low}$	$\geq -44$ dBm
Blocking at $\pm 5$ % of Centre Frequency or 15 MHz, whichever is the greater	$\geq -44$ dBm

**Table 42: Blocking level parameters for RX category 1.5**

Requirement	Limits
	Receiver category 1.5
Blocking at $\pm 2$ MHz from OC edge $f_{high}$ and $f_{low}$	$\geq -43$ dBm
Blocking at $\pm 10$ MHz from OC edge $f_{high}$ and $f_{low}$	$\geq -33$ dBm
Blocking at $\pm 5$ % of Centre Frequency or 15 MHz, whichever is the greater	$\geq -33$ dBm

**Table 43: Blocking level parameters for RX category 1**

Requirement	Limits
	Receiver category 1
Blocking at $\pm 2$ MHz from Centre Frequency	$\geq -20$ dBm
Blocking at $\pm 10$ MHz from Centre Frequency	$\geq -20$ dBm
Blocking at $\pm 5$ % of Centre Frequency or 15 MHz, whichever is the greater	$\geq -20$ dBm

### 14.2 Test Setup

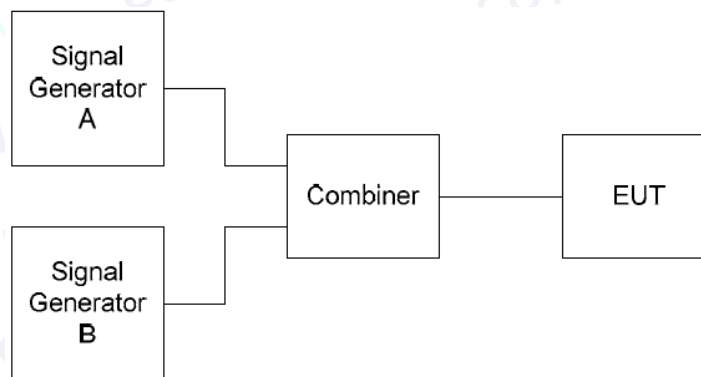

### 14.3 Test Procedure

Signal generator A shall be set to an appropriate modulated test signal at the operating frequency of the EUT receiver.

Signal generator B shall be unmodulated.

Measurements shall be carried out at frequencies of the unwanted signal at approximately the frequency(ies) offset(s) defined in technical requirement avoiding those frequencies at which spurious responses occur.

Additional measurement points may be requested by technical requirements clause.

If several operational frequency bands are used by the equipment, at least one blocking measurement by bands has to be performed.

**Step 1:**

Signal generator B shall be powered off. Signal generator A shall be set to the minimum level which gives the wanted performance criterion of EUT or the reference level in Table 32, whichever is the higher. The output level of generator A shall then be increased by 3 dB unless otherwise specified in technical requirement.

**Step 2:**

Signal generator B is powered on and set to operate at the nominal operating frequency - offset frequency.

Signal generator B is then switched on and the signal amplitude is adjusted to the minimum level at which the wanted performance criterion is not achieved.

With signal generator B settings unchanged, the receiver shall be replaced with a suitable RF power measuring equipment. The power into the measuring equipment shall be measured and noted.

The blocking level is then the conducted power received from generator B at the EUT antenna connector.

This can either be measured on the antenna connector for conducted test or be calculated for radiated test (see clause C.5.4).

The blocking level shall be higher or equal to the blocking power level requested in the technical requirement clause.

**Step 3:**

The measurement in steps 1 to 3 shall be repeated with signal offsets at required frequencies.

**Step 4:**

The information shown in Table 44 shall be recorded in the test report for each measured signal level and unwanted signal offset.

**Table 44: Information Recorded in the Test Report**

Value	Notes
Operating Frequency	Nominal centre frequency of the receiver
Signal generator A	Power level of signal generator A
Blocking level	Power level of signal generator B

For equipment using CCA whatever is the receiver category, steps 1 to 4 shall be repeated with signal generator A level adjusted +13 dB higher than in the measurements in clause 5.18.6.4.

### 14.4 Deviation From Test Standard

No deviation

### 14.5 Test Data

Please refer to the Attachment G.



## 15 Photographs--Test Setup

Radiated Spurious Emission Test Setup (Below 1 GHz)

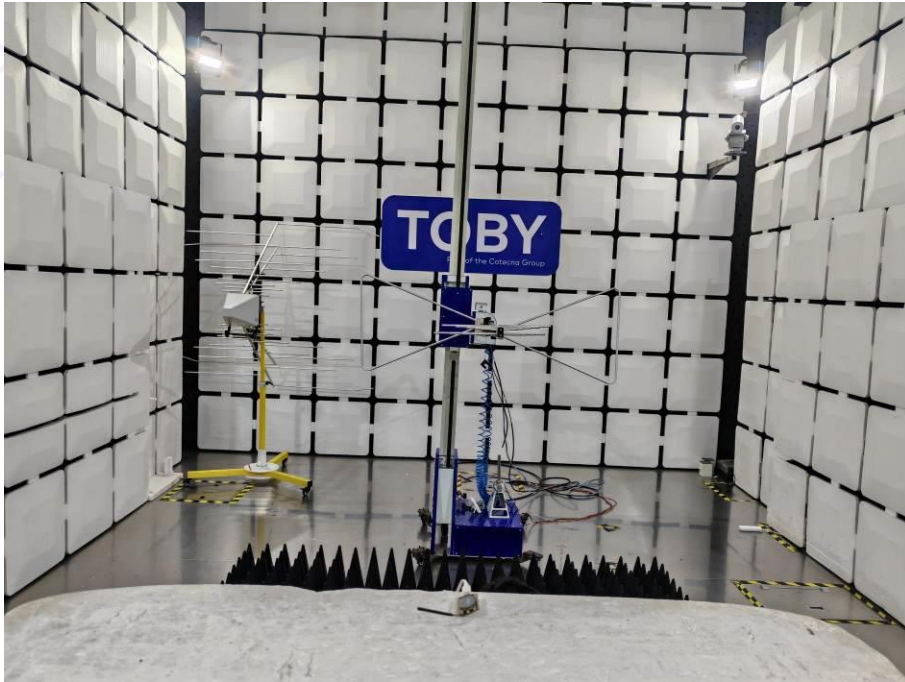

Radiated Spurious Emission Test Setup (Above 1 GHz)

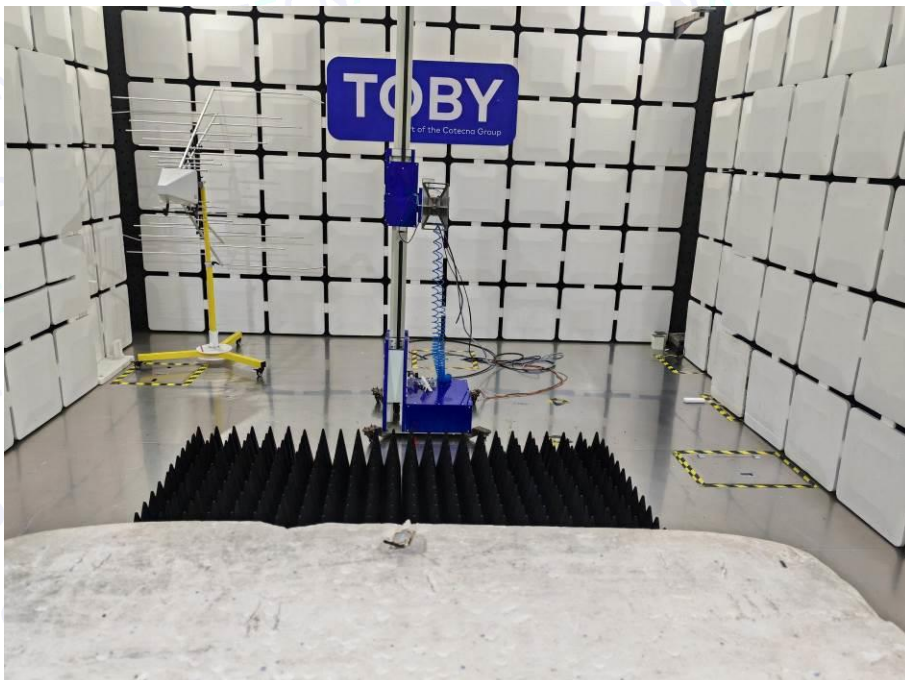

## Attachment A--Unwanted Emissions in the Spurious Domain

<b>Test Mode :</b>		TX Mode 866.5MHz	
<b>Unwanted Emissions in the Spurious Domain with reference BW=126.83kHz</b>			
Frequency Range	RBW	Limit	Results
	(kHz)	(dBm)	(P/F)
$F_c - 4 \times OCW < f < F_c - 2,5 \times OCW$	1kHz	-36 dBm	PASS
$F_c - \text{Max}(10 \times OCW, 500\text{kHz}) < f < F_c - 4 \times OCW$	10kHz	-36 dBm	PASS
$F_c + 2,5 \times OCW < f < F_c + 4 \times OCW$	1kHz	-36 dBm	PASS
$F_c + 4 \times OCW < f < F_c + \text{Max}(10 \times OCW, 500\text{kHz})$	10kHz	-36 dBm	PASS
<b>NOTE:</b> Only showed test data of the worst mode			



**Below 1G**

Test Voltage:	DC 5V
Ant. Pol.	Horizontal
Test Mode:	TX Mode (863.1MHz)
Remark:	Only showed test data of the worst mode.

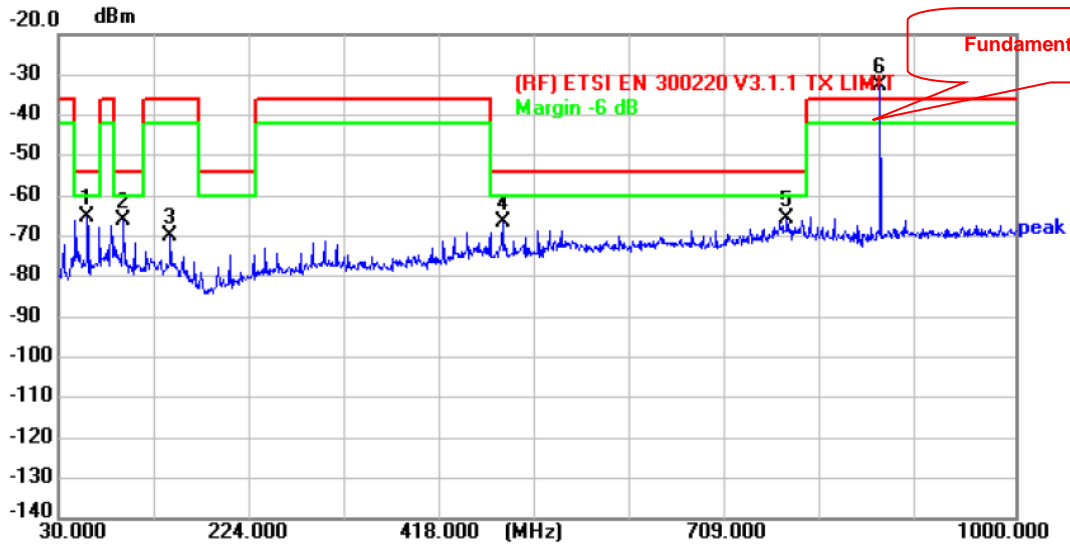

Temperature: 24.5 °C

Humidity: 51 %

No.	Frequency (MHz)	Reading (dBm)	Factor (dB)	Level (dBm)	Limit (dBm)	Margin (dB)	Detector
1	59.1000	-54.63	-10.37	-65.00	-54.00	-11.00	peak
2	95.9600	-54.75	-11.17	-65.92	-54.00	-11.92	peak
3	143.4900	-53.77	-16.03	-69.80	-36.00	-33.80	peak
4	480.0800	-61.28	-5.34	-66.62	-54.00	-12.62	peak
5	768.1700	-64.83	-0.60	-65.43	-54.00	-11.43	peak
6 *	863.2300	-32.99	0.43	-32.56	-36.00	3.44	peak

**Remark:**

1. Corr. = Antenna Factor (dB) + Cable Loss (dB)
2. Margin (dB) = Peak(dBm) - Limit (dBm)



Test Voltage:	DC 5V
Ant. Pol.	Vertical
Test Mode:	TX Mode (863.1MHz)
Remark:	Only showed test data of the worst mode.

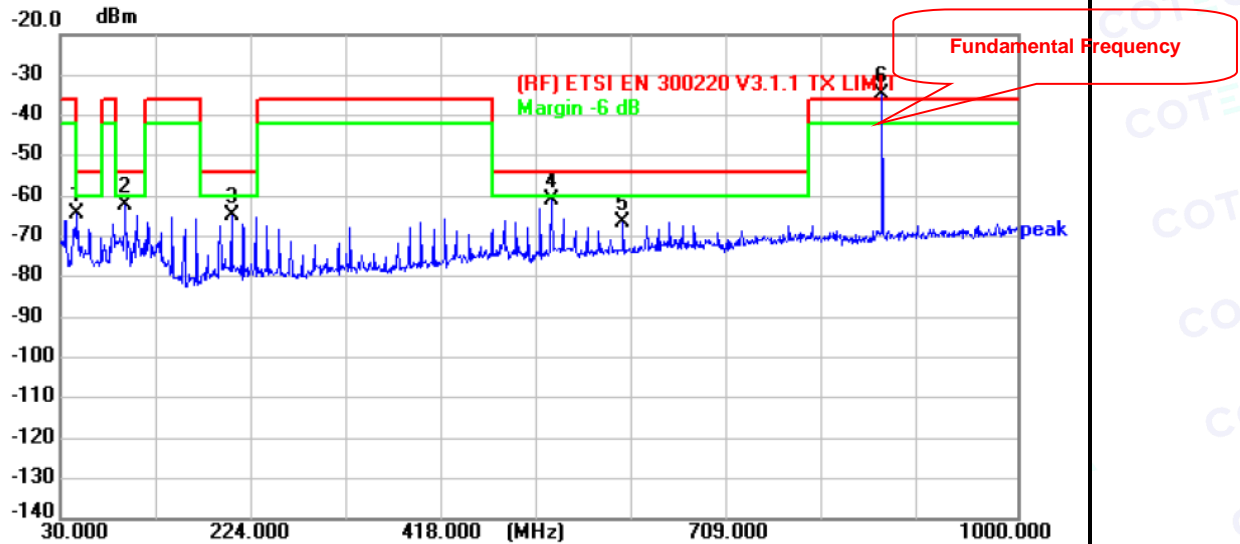

Temperature: 24.5 °C

Humidity: 51 %

No.	Frequency (MHz)	Reading (dBm)	Factor (dB)	Level (dBm)	Limit (dBm)	Margin (dB)	Detector
1	47.4600	-54.44	-9.86	-64.30	-54.00	-10.30	peak
2	95.9600	-50.89	-11.18	-62.07	-54.00	-8.07	peak
3	203.6300	-53.45	-11.23	-64.68	-54.00	-10.68	peak
4	527.6100	-56.16	-4.59	-60.75	-54.00	-6.75	peak
5	600.3600	-63.81	-2.64	-66.45	-54.00	-12.45	peak
6 *	863.2300	-35.02	0.17	-34.85	-36.00	1.15	peak

Remark:

1. Corr. = Antenna Factor (dB) + Cable Loss (dB)

2. Margin (dB) = Peak(dBm) - Limit (dBm)



Test Voltage:	DC 5V
Ant. Pol.	Horizontal
Test Mode:	TX Mode (866.5MHz)
Remark:	Only showed test data of the worst mode.

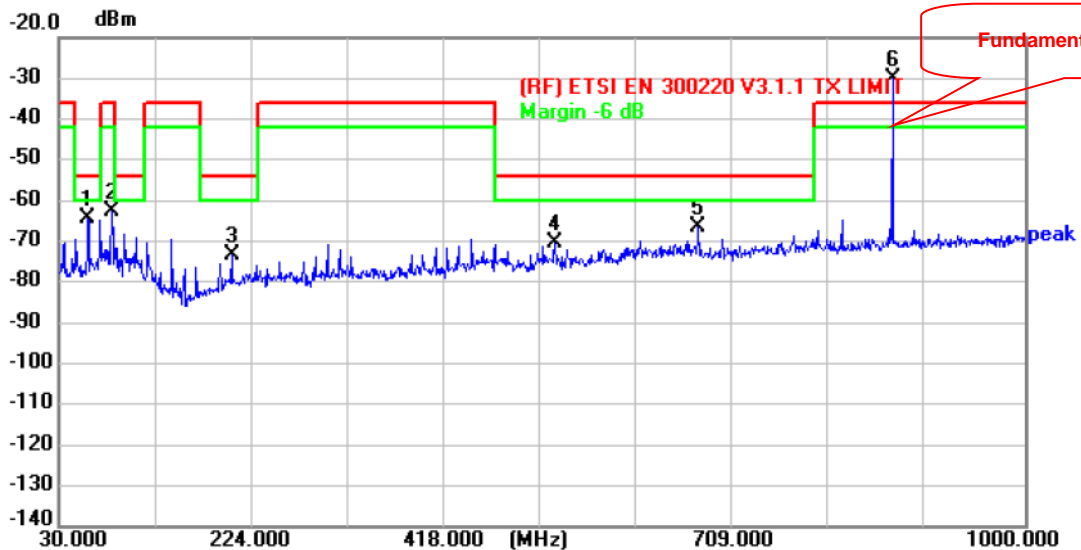

Temperature: 24.5 °C

Humidity: 51 %

No.	Frequency (MHz)	Reading (dBm)	Factor (dB)	Level (dBm)	Limit (dBm)	Margin (dB)	Detector
1	59.1000	-53.99	-10.37	-64.36	-54.00	-10.36	peak
2	83.3500	-49.58	-12.92	-62.50	-36.00	-26.50	peak
3	203.6300	-61.36	-11.82	-73.18	-54.00	-19.18	peak
4	527.6100	-64.86	-5.31	-70.17	-54.00	-16.17	peak
5	672.1400	-64.28	-2.06	-66.34	-54.00	-12.34	peak
6 *	867.1100	-30.54	0.47	-30.07	-36.00	5.93	peak

Remark:

1. Corr. = Antenna Factor (dB) + Cable Loss (dB)
2. Margin (dB) = Peak(dBm) - Limit (dBm)



Test Voltage:	DC 5V
Ant. Pol.	Vertical
Test Mode:	TX Mode (866.5MHz)
Remark:	Only showed test data of the worst mode.

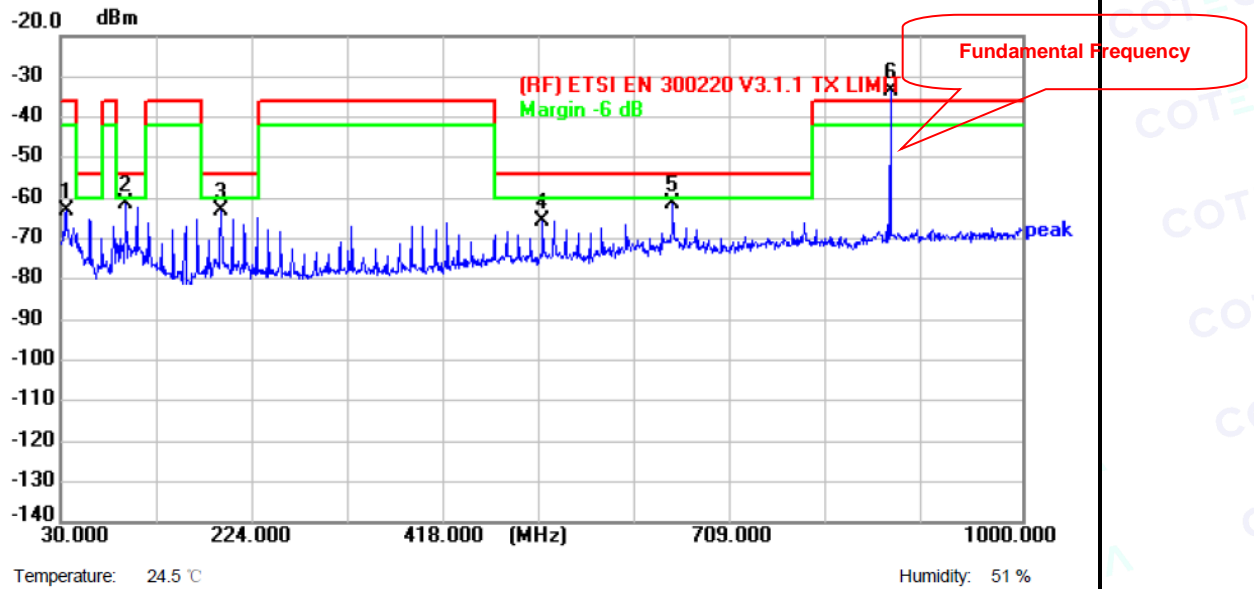

No.	Frequency (MHz)	Reading (dBm)	Factor (dB)	Level (dBm)	Limit (dBm)	Margin (dB)	Detector
1	35.8200	-51.33	-11.80	-63.13	-36.00	-27.13	peak
2	95.9600	-50.29	-11.18	-61.47	-54.00	-7.47	peak
3	191.9900	-51.81	-11.10	-62.91	-54.00	-8.91	peak
4	515.9699	-60.66	-4.87	-65.53	-54.00	-11.53	peak
5	647.8900	-58.80	-2.74	-61.54	-54.00	-7.54	peak
6 *	867.1100	-33.58	0.16	-33.42	-36.00	2.58	peak

Remark:  
 1. Corr. = Antenna Factor (dB) + Cable Loss (dB)  
 2. Margin (dB) = Peak(dBm) - Limit (dBm)



Test Voltage:	DC 5V
Ant. Pol.	Horizontal
Test Mode:	TX Mode (869.9MHz)
Remark:	Only showed test data of the worst mode.

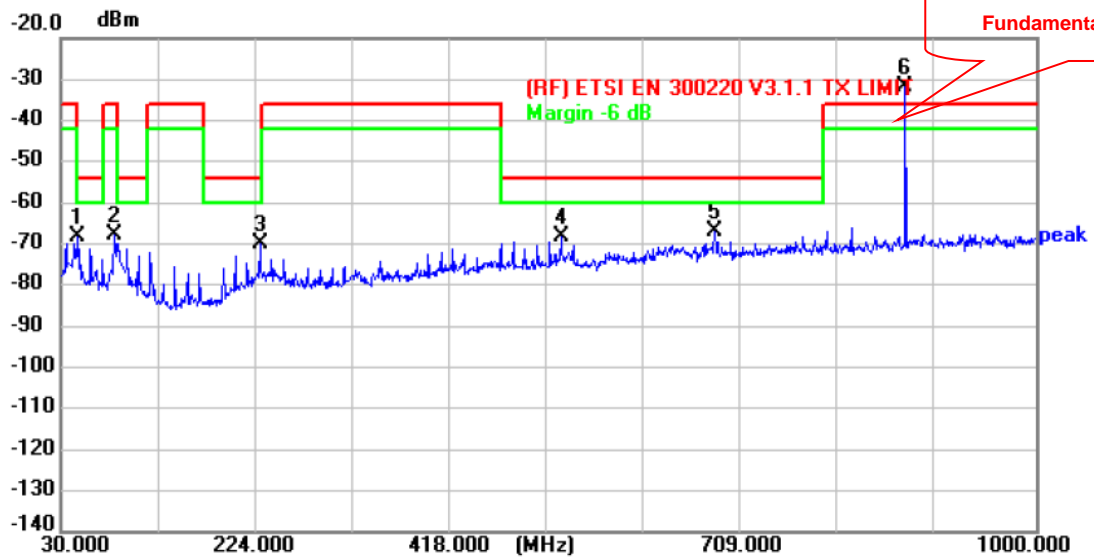

Temperature: 24.5 °C

Humidity: 51 %

No.	Frequency (MHz)	Reading (dBm)	Factor (dB)	Level (dBm)	Limit (dBm)	Margin (dB)	Detector
1	47.4600	-60.06	-8.27	-68.33	-54.00	-14.33	peak
2	83.3500	-54.76	-12.92	-67.68	-36.00	-31.68	peak
3	227.8800	-59.61	-10.27	-69.88	-54.00	-15.88	peak
4	527.6100	-63.02	-5.31	-68.33	-54.00	-14.33	peak
5	680.8700	-64.83	-2.23	-67.06	-54.00	-13.06	peak
6 *	870.0200	-32.39	0.49	-31.90	-36.00	4.10	peak

**Remark:**

1. Corr. = Antenna Factor (dB) + Cable Loss (dB)

2. Margin (dB) = Peak(dBm) - Limit (dBm)



Test Voltage:	DC 5V
Ant. Pol.	Vertical
Test Mode:	TX Mode (869.9MHz)
Remark:	Only showed test data of the worst mode.

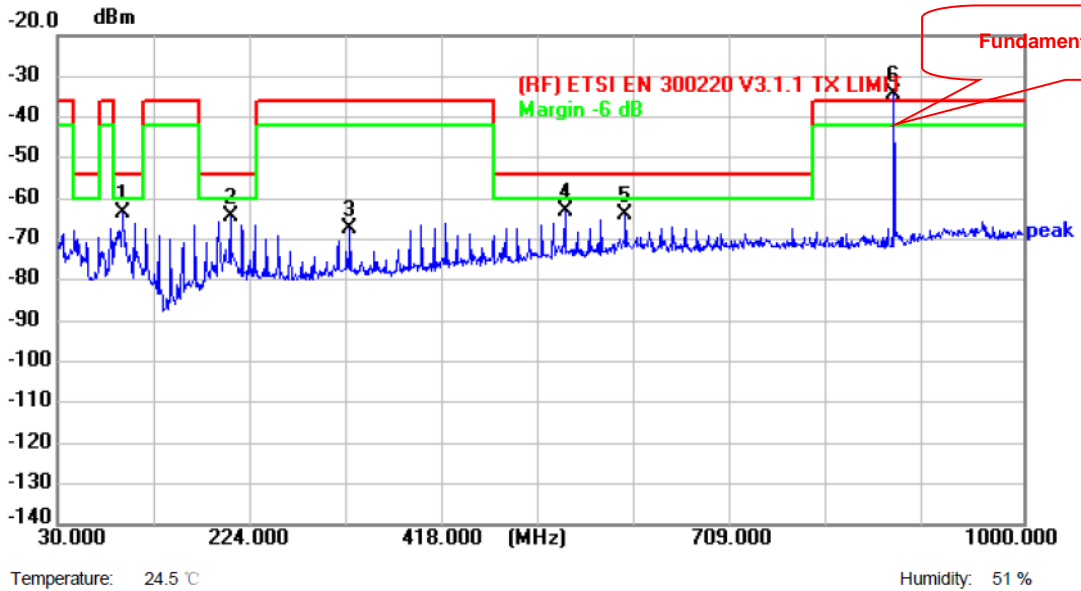

No.	Frequency (MHz)	Reading (dBm)	Factor (dB)	Level (dBm)	Limit (dBm)	Margin (dB)	Detector
1	95.9600	-52.15	-11.18	-63.33	-54.00	-9.33	peak
2	203.6300	-52.92	-11.23	-64.15	-54.00	-10.15	peak
3	323.9100	-58.35	-8.87	-67.22	-36.00	-31.22	peak
4	540.2199	-58.46	-4.41	-62.87	-54.00	-8.87	peak
5	600.3600	-61.21	-2.64	-63.85	-54.00	-9.85	peak
6 *	870.0200	-34.61	0.14	-34.47	-36.00	1.53	peak

Remark:  
 1. Corr. = Antenna Factor (dB) + Cable Loss (dB)  
 2. Margin (dB) = Peak(dBm) - Limit (dBm)



Test Voltage:	DC 5V
Ant. Pol.	Horizontal
Test Mode:	RX Mode (863.1MHz)
Remark:	Only showed test data of the worst mode.

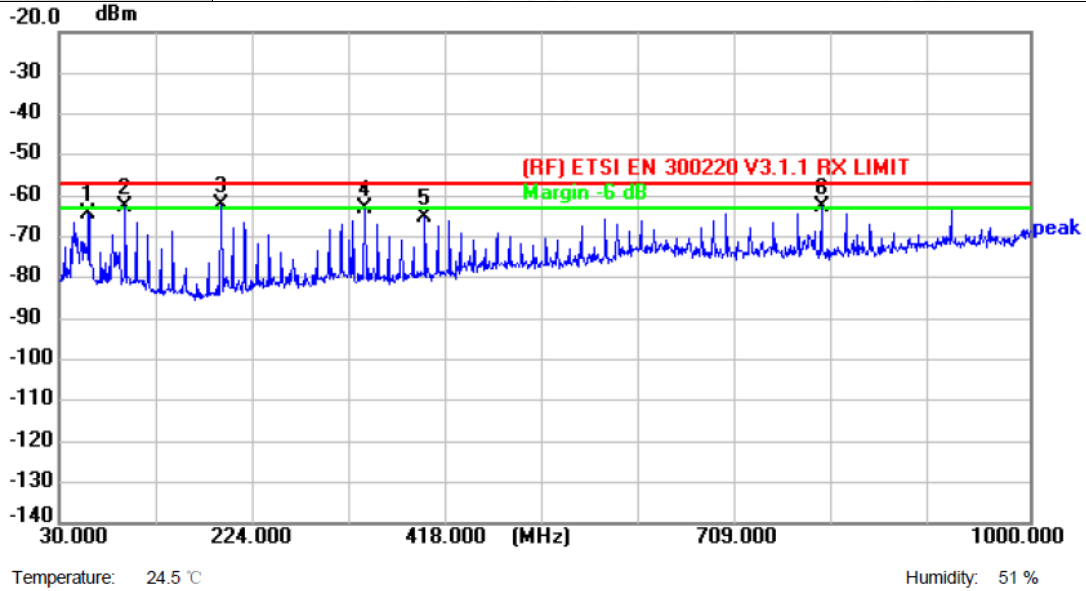

No.	Frequency (MHz)	Reading (dBm)	Factor (dB)	Level (dBm)	Limit (dBm)	Margin (dB)	Detector
1	59.1000	-53.84	-10.37	-64.21	-57.00	-7.21	peak
2 !	95.9600	-51.56	-11.17	-62.73	-57.00	-5.73	peak
3 *	191.9900	-49.05	-13.09	-62.14	-57.00	-5.14	peak
4	335.5500	-55.05	-8.18	-63.23	-57.00	-6.23	peak
5	395.6900	-58.07	-7.07	-65.14	-57.00	-8.14	peak
6 !	792.4200	-62.08	-0.57	-62.65	-57.00	-5.65	peak

Remark:  
 1. Corr. = Antenna Factor (dB) + Cable Loss (dB)  
 2. Margin (dB) = Peak(dBm) - Limit (dBm)



Test Voltage:	DC 5V
Ant. Pol.	Vertical
Test Mode:	RX Mode (863.1MHz)
Remark:	Only showed test data of the worst mode.

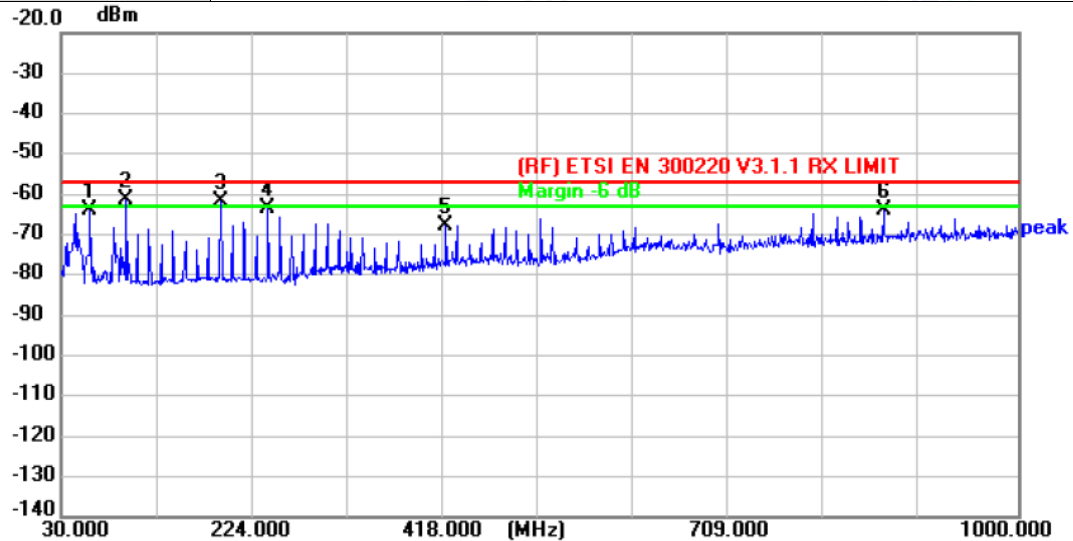

Temperature: 24.5 °C

Humidity: 51 %

No.	Frequency (MHz)	Reading (dBm)	Factor (dB)	Level (dBm)	Limit (dBm)	Margin (dB)	Detector
1	59.1000	-53.43	-10.48	-63.91	-57.00	-6.91	peak
2 *	95.9600	-50.38	-11.18	-61.56	-57.00	-4.56	peak
3 !	191.9900	-50.70	-11.10	-61.80	-57.00	-4.80	peak
4	239.5200	-52.04	-11.67	-63.71	-57.00	-6.71	peak
5	419.9400	-61.07	-6.55	-67.62	-57.00	-10.62	peak
6	864.2000	-64.27	0.16	-64.11	-57.00	-7.11	peak

Remark:

1. Corr. = Antenna Factor (dB) + Cable Loss (dB)

2. Margin (dB) = Peak(dBm) - Limit (dBm)



Test Voltage:	DC 5V
Ant. Pol.	Horizontal
Test Mode:	RX Mode (866.5MHz)
Remark:	Only showed test data of the worst mode.

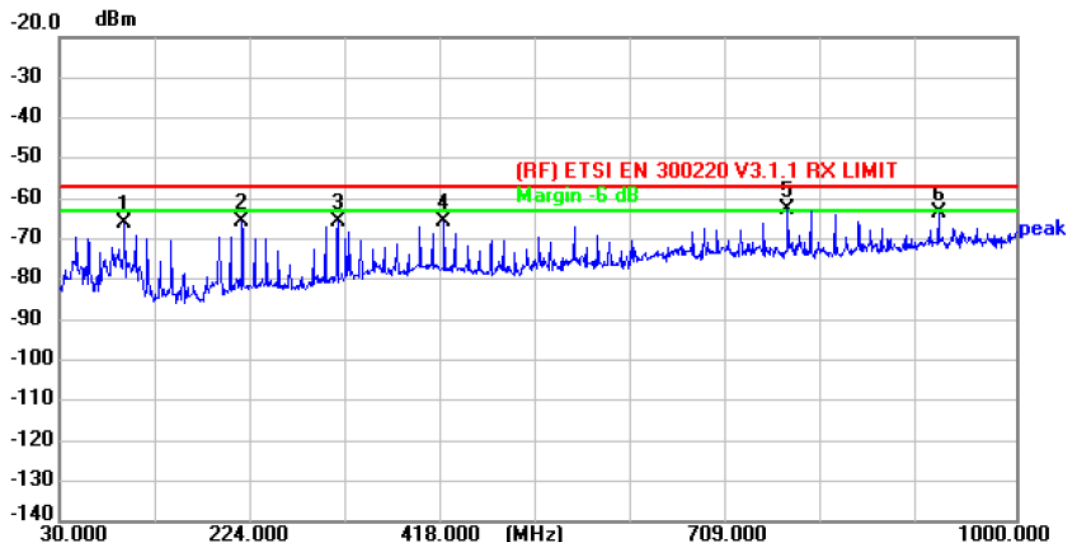

Temperature: 24.5 °C

Humidity: 51 %

No.	Frequency (MHz)	Reading (dBm)	Factor (dB)	Level (dBm)	Limit (dBm)	Margin (dB)	Detector
1	95.9600	-54.83	-11.17	-66.00	-57.00	-9.00	peak
2	215.2700	-54.49	-11.33	-65.82	-57.00	-8.82	peak
3	312.2700	-57.63	-8.07	-65.70	-57.00	-8.70	peak
4	419.9400	-59.01	-6.58	-65.59	-57.00	-8.59	peak
5 *	768.1700	-61.98	-0.60	-62.58	-57.00	-5.58	peak
6	921.4300	-64.50	1.05	-63.45	-57.00	-6.45	peak

Remark:

1. Corr. = Antenna Factor (dB) + Cable Loss (dB)

2. Margin (dB) = Peak(dBm) - Limit (dBm)



Test Voltage:	DC 5V
Ant. Pol.	Vertical
Test Mode:	RX Mode (866.5MHz)
Remark:	Only showed test data of the worst mode.

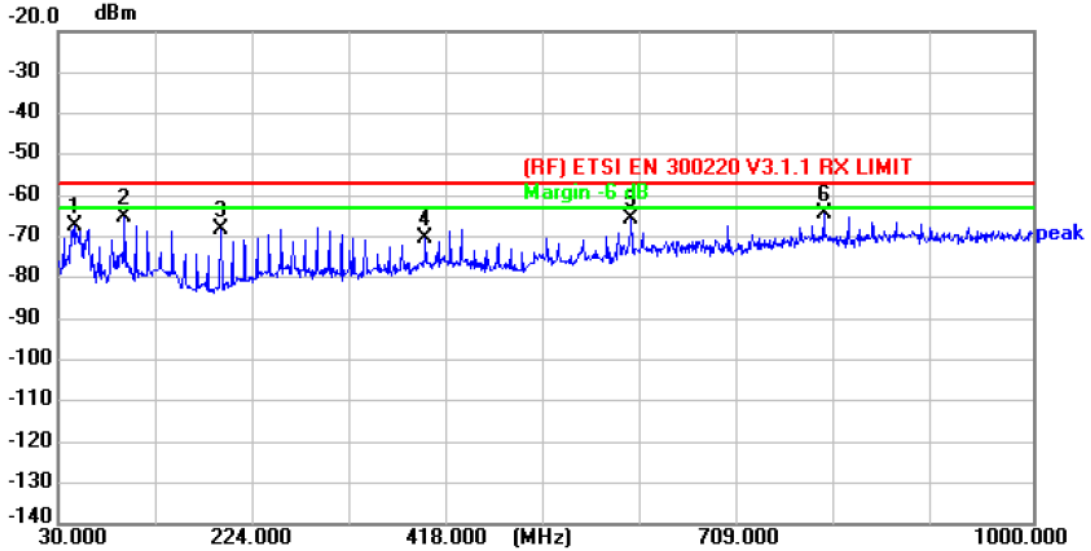

Temperature: 24.5 °C

Humidity: 51 %

No.	Frequency (MHz)	Reading (dBm)	Factor (dB)	Level (dBm)	Limit (dBm)	Margin (dB)	Detector
1	47.4600	-57.59	-9.86	-67.45	-57.00	-10.45	peak
2	95.9600	-54.23	-11.18	-65.41	-57.00	-8.41	peak
3	191.9900	-57.29	-11.10	-68.39	-57.00	-11.39	peak
4	395.6900	-63.73	-6.56	-70.29	-57.00	-13.29	peak
5	600.3600	-62.90	-2.64	-65.54	-57.00	-8.54	peak
6 *	792.4200	-63.52	-0.73	-64.25	-57.00	-7.25	peak

Remark:

1. Corr. = Antenna Factor (dB) + Cable Loss (dB)
2. Margin (dB) = Peak(dBm)-Limit (dBm)



Test Voltage:	DC 5V
Ant. Pol.	Horizontal
Test Mode:	RX Mode (869.9MHz)
Remark:	Only showed test data of the worst mode.

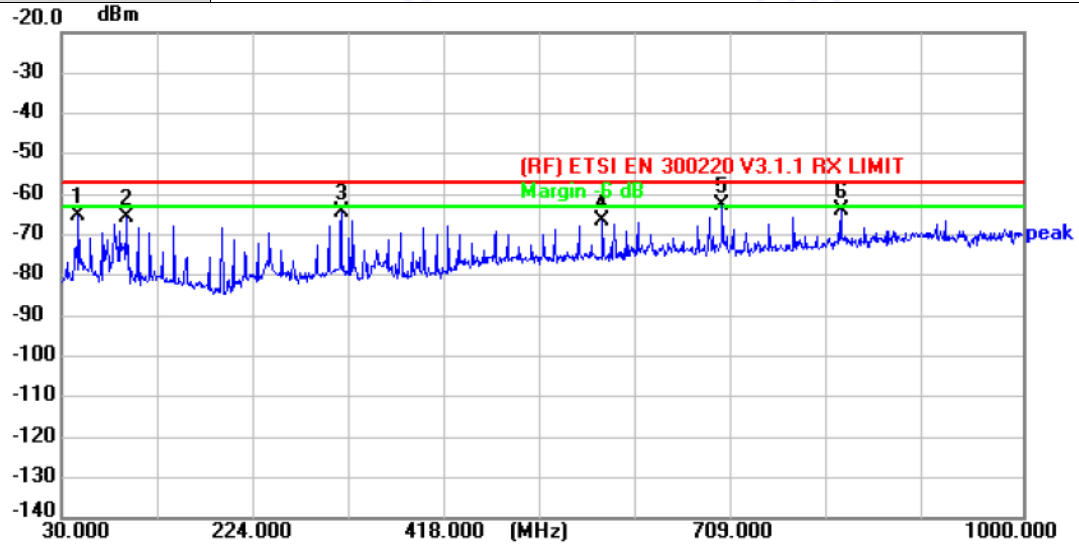

Temperature: 24.5 °C

Humidity: 51 %

No.	Frequency (MHz)	Reading (dBm)	Factor (dB)	Level (dBm)	Limit (dBm)	Margin (dB)	Detector
1	47.4600	-56.84	-8.27	-65.11	-57.00	-8.11	peak
2	95.9600	-54.60	-11.17	-65.77	-57.00	-8.77	peak
3	312.2700	-56.44	-8.07	-64.51	-57.00	-7.51	peak
4	576.1100	-62.06	-4.28	-66.34	-57.00	-9.34	peak
5 *	696.3900	-60.45	-2.14	-62.59	-57.00	-5.59	peak
6	816.6700	-63.44	-0.53	-63.97	-57.00	-6.97	peak

Remark:

1. Corr. = Antenna Factor (dB) + Cable Loss (dB)

2. Margin (dB) = Peak(dBm) - Limit (dBm)



Test Voltage:	DC 5V
Ant. Pol.	Vertical
Test Mode:	RX Mode (869.9MHz)
Remark:	Only showed test data of the worst mode.

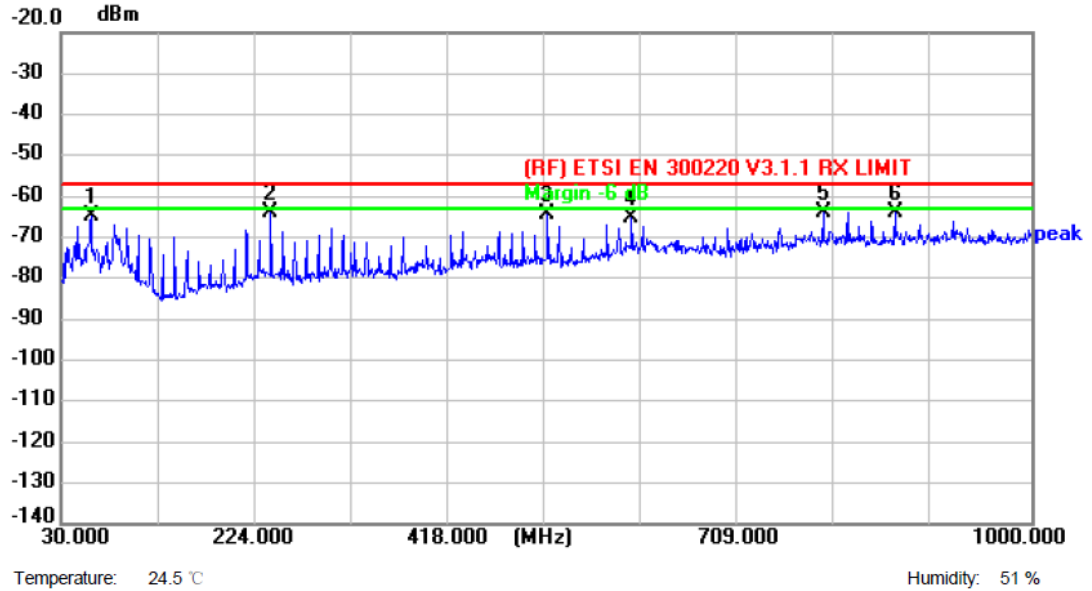

No.	Frequency (MHz)	Reading (dBm)	Factor (dB)	Level (dBm)	Limit (dBm)	Margin (dB)	Detector
1	60.0700	-54.34	-10.59	-64.93	-57.00	-7.93	peak
2	239.5200	-52.35	-11.67	-64.02	-57.00	-7.02	peak
3	515.9699	-59.64	-4.87	-64.51	-57.00	-7.51	peak
4	600.3600	-62.73	-2.64	-65.37	-57.00	-8.37	peak
5 *	792.4200	-63.11	-0.73	-63.84	-57.00	-6.84	peak
6	864.2000	-64.14	0.16	-63.98	-57.00	-6.98	peak

Remark:  
 1. Corr. = Antenna Factor (dB) + Cable Loss (dB)  
 2. Margin (dB) = Peak(dBm) - Limit (dBm)



Above 1G

Test Voltage:	DC 5V
Ant. Pol.	Horizontal
Test Mode:	TX Mode (863.1MHz)
Remark:	Only showed test data of the worst mode.

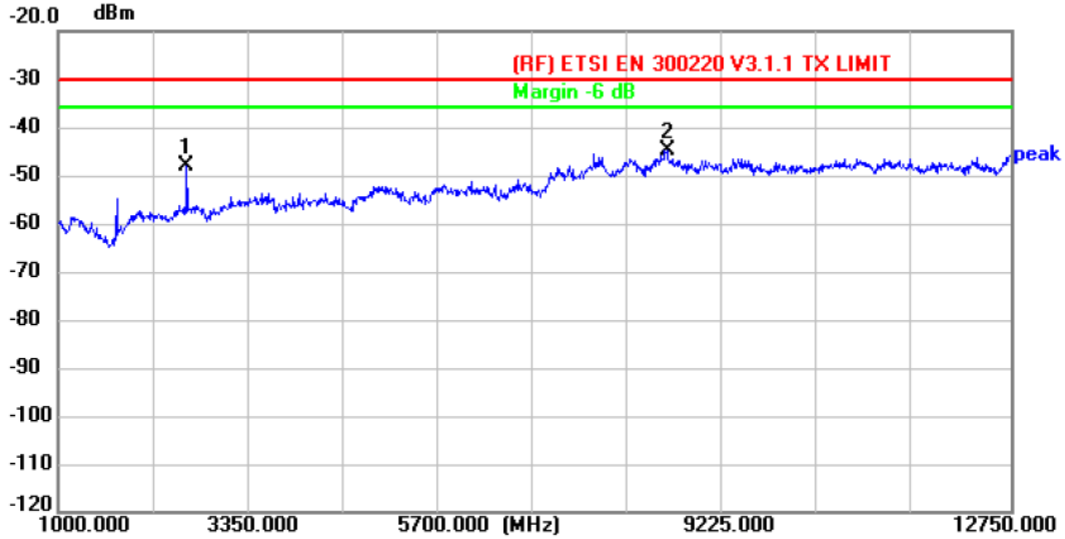

Temperature: 24.5 °C

Humidity: 51 %

No.	Frequency (MHz)	Reading (dBm)	Factor (dB)	Level (dBm)	Limit (dBm)	Margin (dB)	Detector
1	2586.2500	-44.78	-3.10	-47.88	-30.00	-17.88	peak
2 *	8508.2500	-57.46	12.54	-44.92	-30.00	-14.92	peak

Remark:

1. Corr. = Antenna Factor (dB) + Cable Loss (dB)
2. Margin (dB) = Peak(dBm) - Limit (dBm)
3. The tests evaluated 1~12.75GHz, Test with highpass filter (Pass Frequency: 2.8-18G).
4. No report for the emission which below the prescribed limit.



Test Voltage:	DC 5V
Ant. Pol.	Vertical
Test Mode:	TX Mode (863.1MHz)
Remark:	Only showed test data of the worst mode.

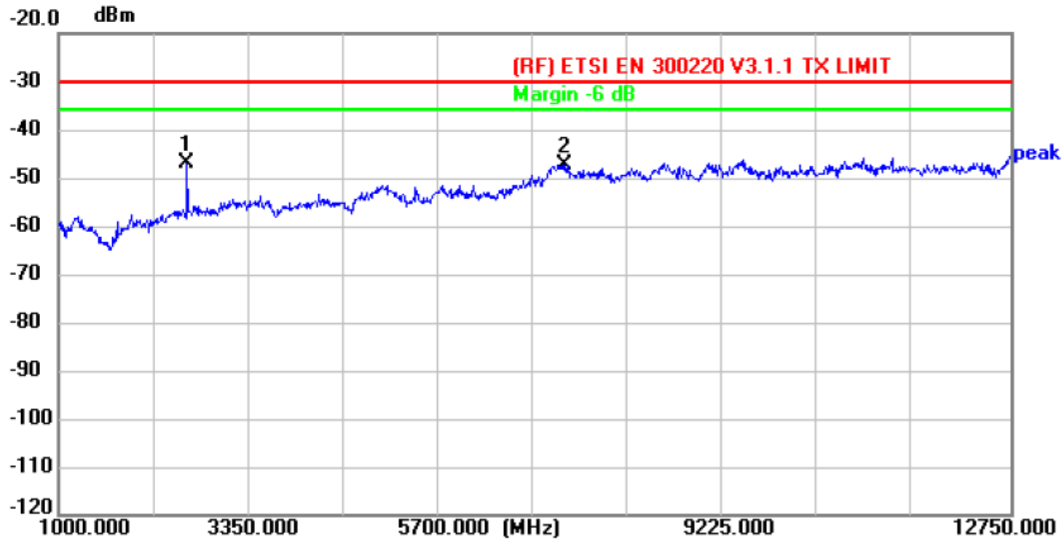

Temperature: 24.5 °C

Humidity: 51 %

No.	Frequency (MHz)	Reading (dBm)	Factor (dB)	Level (dBm)	Limit (dBm)	Margin (dB)	Detector
1 *	2586.2500	-43.61	-3.21	-46.82	-30.00	-16.82	peak
2	7251.0000	-56.23	9.03	-47.20	-30.00	-17.20	peak

**Remark:**

1. Corr. = Antenna Factor (dB) + Cable Loss (dB)
2. Margin (dB) = Peak(dBm)-Limit (dBm)
3. The tests evaluated 1~12.75GHz, Test with highpass filter (Pass Frequency: 2.8-18G).
4. No report for the emission which below the prescribed limit.



Test Voltage:	DC 5V
Ant. Pol.	Horizontal
Test Mode:	TX Mode (866.5MHz)
Remark:	Only showed test data of the worst mode.

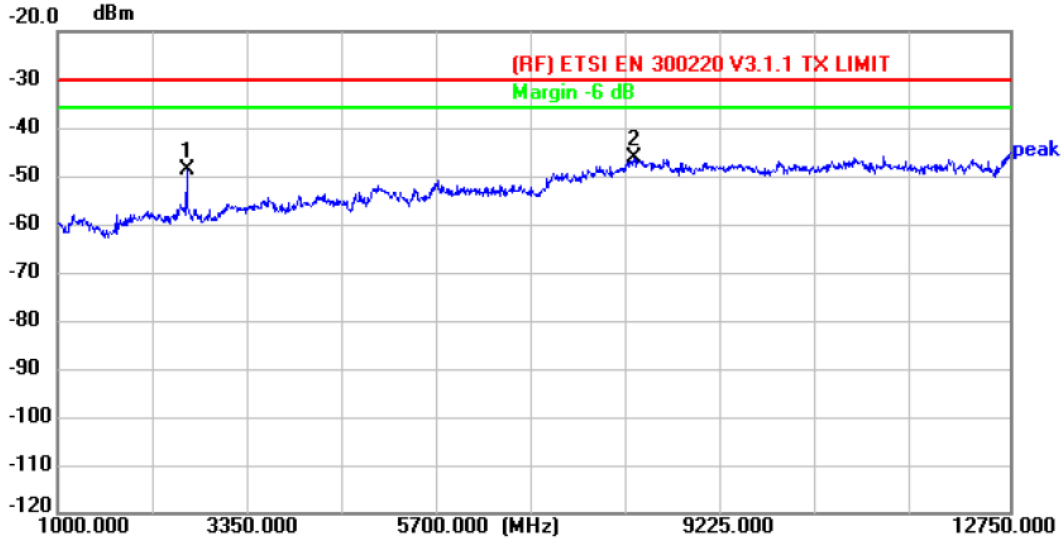

Temperature: 24.5 °C

Humidity: 51 %

No.	Frequency (MHz)	Reading (dBm)	Factor (dB)	Level (dBm)	Limit (dBm)	Margin (dB)	Detector
1	2598.0000	-45.52	-3.15	-48.67	-30.00	-18.67	peak
2 *	8120.5000	-57.03	10.68	-46.35	-30.00	-16.35	peak

**Remark:**

1. Corr. = Antenna Factor (dB) + Cable Loss (dB)
2. Margin (dB) = Peak(dBm) - Limit (dBm)
3. The tests evaluated 1~12.75GHz, Test with highpass filter (Pass Frequency: 2.8-18G).
4. No report for the emission which below the prescribed limit.



Test Voltage:	DC 5V
Ant. Pol.	Vertical
Test Mode:	TX Mode (866.5MHz)
Remark:	Only showed test data of the worst mode.

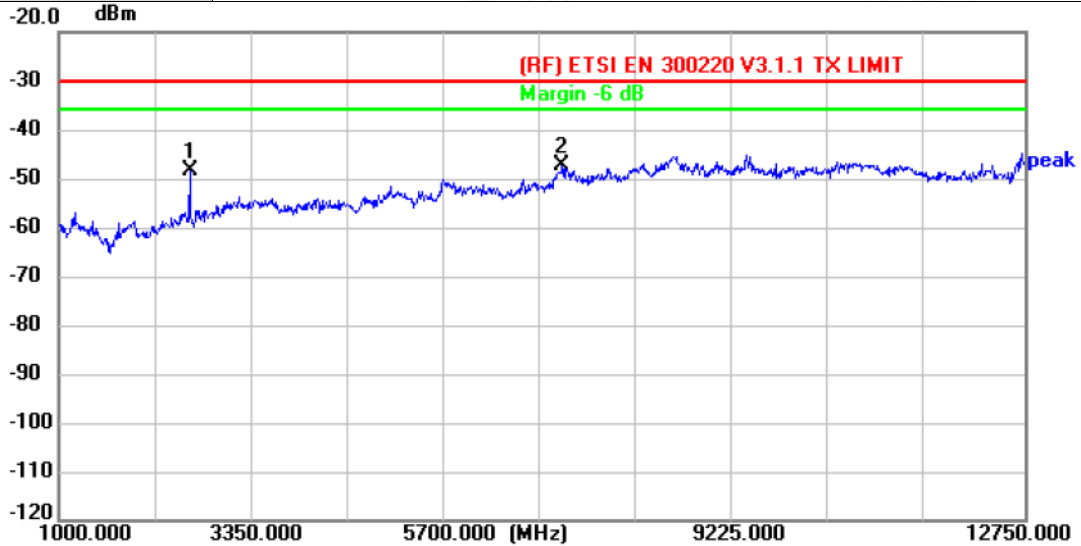

Temperature: 24.5 °C

Humidity: 51 %

No.	Frequency (MHz)	Reading (dBm)	Factor (dB)	Level (dBm)	Limit (dBm)	Margin (dB)	Detector
1	2598.0000	-45.15	-3.32	-48.47	-30.00	-18.47	peak
2 *	7121.7500	-56.89	9.42	-47.47	-30.00	-17.47	peak

**Remark:**

1. Corr. = Antenna Factor (dB) + Cable Loss (dB)
2. Margin (dB) = Peak(dBm)-Limit (dBm)
3. The tests evaluated 1~12.75GHz, Test with highpass filter (Pass Frequency: 2.8-18G).
4. No report for the emission which below the prescribed limit.



Test Voltage:	DC 5V
Ant. Pol.	Horizontal
Test Mode:	TX Mode (869.9MHz)
Remark:	Only showed test data of the worst mode.

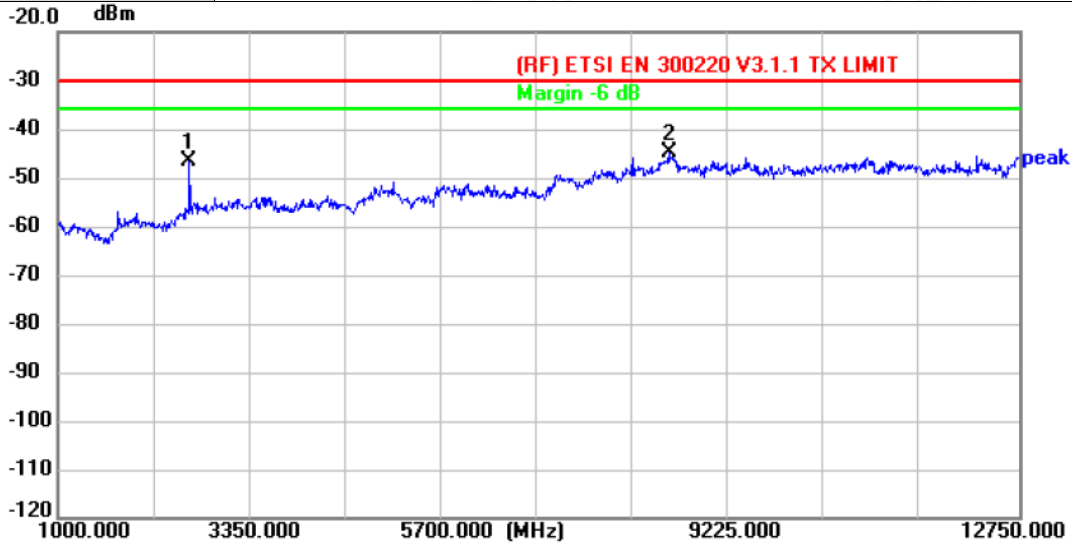

Temperature: 24.5 °C

Humidity: 51 %

No.	Frequency (MHz)	Reading (dBm)	Factor (dB)	Level (dBm)	Limit (dBm)	Margin (dB)	Detector
1	2609.7500	-43.72	-3.06	-46.78	-30.00	-16.78	peak
2 *	8473.0000	-57.22	12.27	-44.95	-30.00	-14.95	peak

**Remark:**

1. Corr. = Antenna Factor (dB) + Cable Loss (dB)
2. Margin (dB) = Peak(dBm) - Limit (dBm)
3. The tests evaluated 1~12.75GHz, Test with highpass filter (Pass Frequency: 2.8-18G).
4. No report for the emission which below the prescribed limit.



Test Voltage:	DC 5V
Ant. Pol.	Vertical
Test Mode:	TX Mode (869.9MHz)
Remark:	Only showed test data of the worst mode.

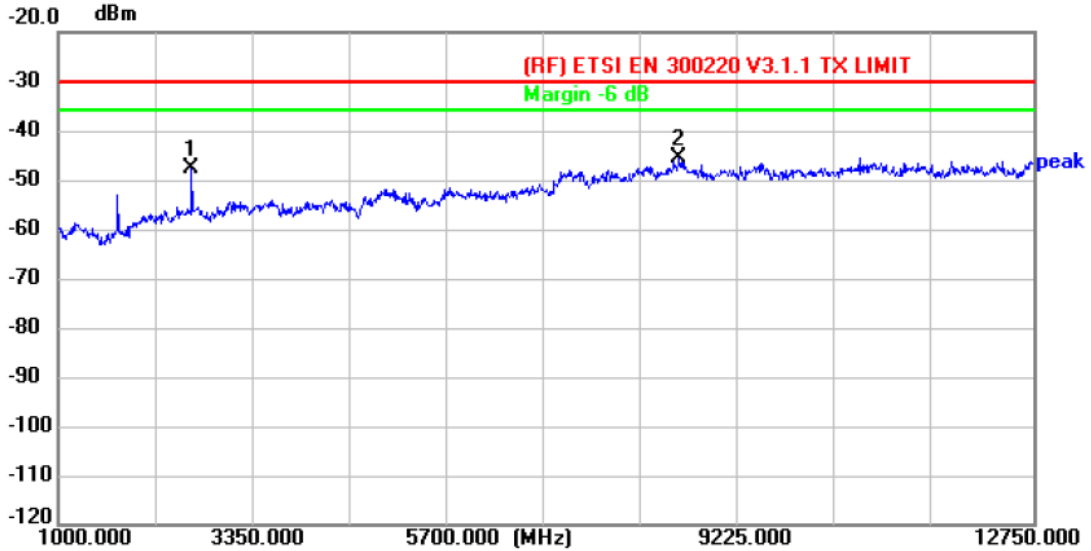

Temperature: 24.5 °C

Humidity: 51 %

No.	Frequency (MHz)	Reading (dBm)	Factor (dB)	Level (dBm)	Limit (dBm)	Margin (dB)	Detector
1	2609.7500	-44.36	-3.21	-47.57	-30.00	-17.57	peak
2 *	8484.7500	-58.25	12.78	-45.47	-30.00	-15.47	peak

**Remark:**

1. Corr. = Antenna Factor (dB) + Cable Loss (dB)
2. Margin (dB) = Peak(dBm) - Limit (dBm)
3. The tests evaluated 1~12.75GHz, Test with highpass filter (Pass Frequency: 2.8-18G).
4. No report for the emission which below the prescribed limit.



Test Voltage:	DC 5V
Ant. Pol.	Horizontal
Test Mode:	RX Mode (863.1MHz)
Remark:	Only showed test data of the worst mode.

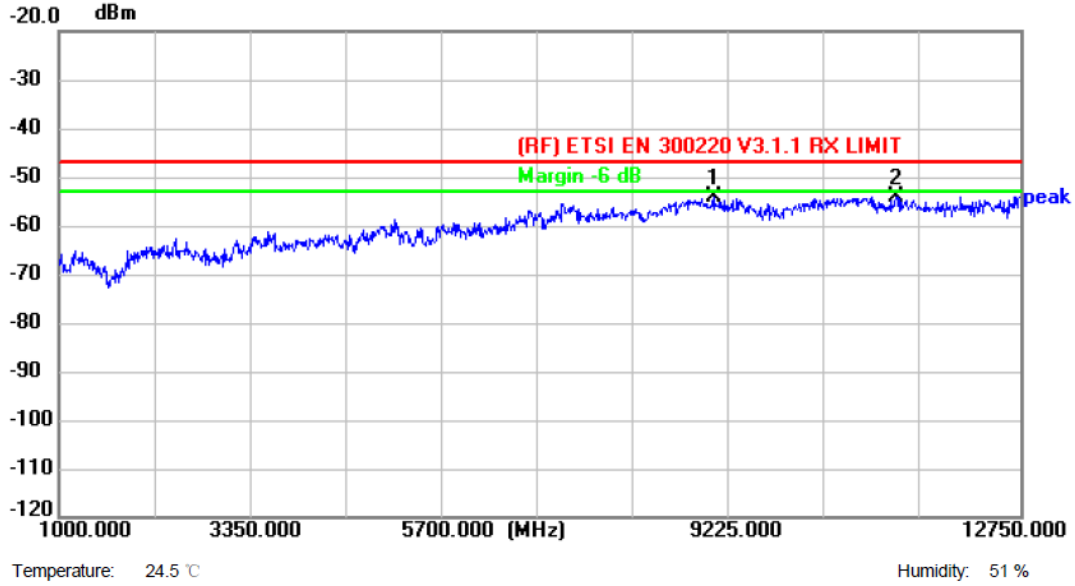

No.	Frequency (MHz)	Reading (dBm)	Factor (dB)	Level (dBm)	Limit (dBm)	Margin (dB)	Detector
1	9001.7500	-60.17	6.14	-54.03	-47.00	-7.03	peak
2 *	11234.2500	-64.38	10.39	-53.99	-47.00	-6.99	peak

Remark:

1. Corr. = Antenna Factor (dB) + Cable Loss (dB)
2. Margin (dB) = Peak(dBm) - Limit (dBm)
3. The tests evaluated 1~12.75GHz, Test with highpass filter (Pass Frequency: 2.8-18G).
4. No report for the emission which below the prescribed limit.



Test Voltage:	DC 5V
Ant. Pol.	Vertical
Test Mode:	RX Mode (863.1MHz)
Remark:	Only showed test data of the worst mode.

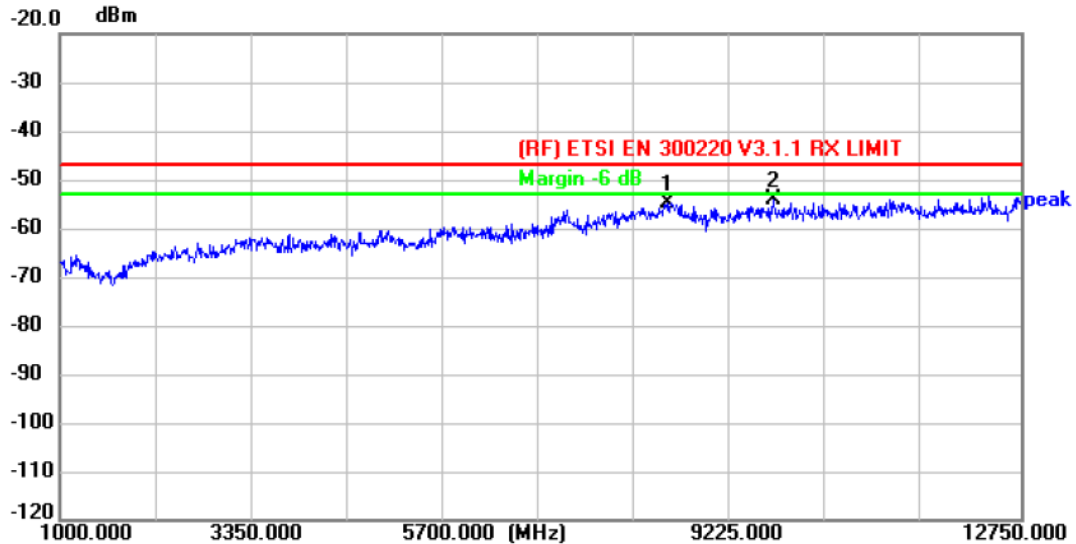

Temperature: 24.5 °C

Humidity: 51 %

No.	Frequency (MHz)	Reading (dBm)	Factor (dB)	Level (dBm)	Limit (dBm)	Margin (dB)	Detector
1	8437.7500	-60.96	6.27	-54.69	-47.00	-7.69	peak
2 *	9730.2500	-61.24	7.08	-54.16	-47.00	-7.16	peak

**Remark:**

1. Corr. = Antenna Factor (dB) + Cable Loss (dB)
2. Margin (dB) = Peak(dBm)-Limit (dBm)
3. The tests evaluated 1~12.75GHz, Test with highpass filter (Pass Frequency: 2.8-18G).
4. No report for the emission which below the prescribed limit.



Test Voltage:	DC 5V
Ant. Pol.	Horizontal
Test Mode:	RX Mode (866.5MHz)
Remark:	Only showed test data of the worst mode.

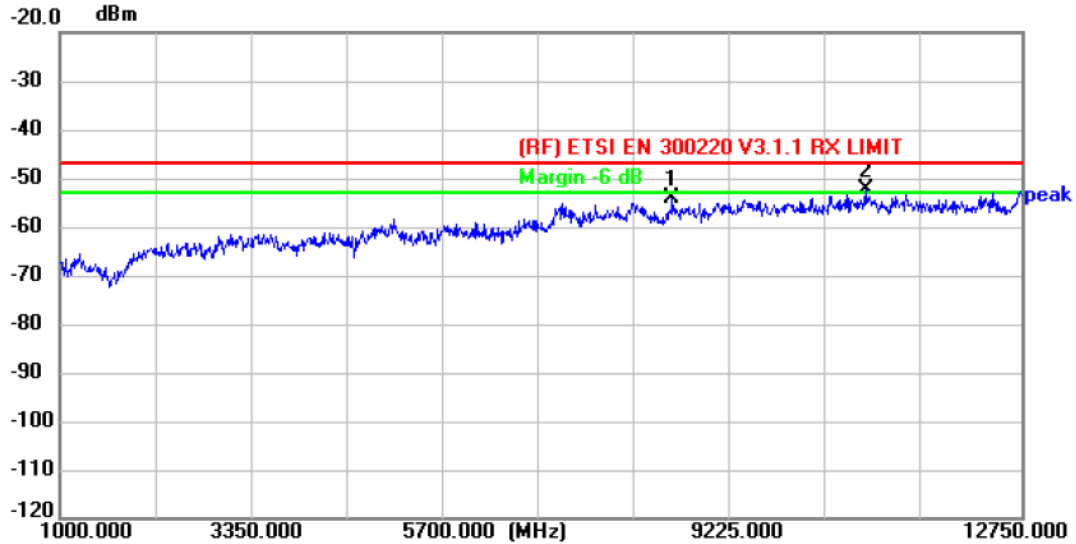

Temperature: 24.5 °C

Humidity: 51 %

No.	Frequency (MHz)	Reading (dBm)	Factor (dB)	Level (dBm)	Limit (dBm)	Margin (dB)	Detector
1	8484.7500	-60.83	6.78	-54.05	-47.00	-7.05	peak
2 *	10846.5000	-61.96	9.61	-52.35	-47.00	-5.35	peak

**Remark:**

1. Corr. = Antenna Factor (dB) + Cable Loss (dB)
2. Margin (dB) = Peak(dBm) - Limit (dBm)
3. The tests evaluated 1~12.75GHz, Test with highpass filter (Pass Frequency: 2.8-18G).
4. No report for the emission which below the prescribed limit.



Test Voltage:	DC 5V
Ant. Pol.	Vertical
Test Mode:	RX Mode (866.5MHz)
Remark:	Only showed test data of the worst mode.

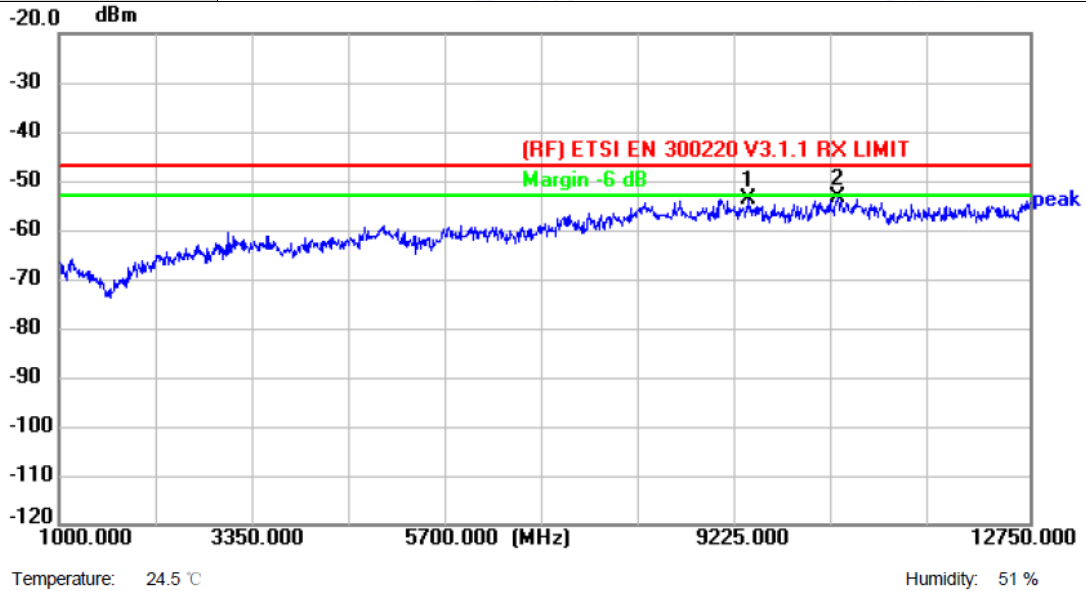

No.	Frequency (MHz)	Reading (dBm)	Factor (dB)	Level (dBm)	Limit (dBm)	Margin (dB)	Detector
1	9354.2500	-60.77	6.95	-53.82	-47.00	-6.82	peak
2 *	10435.2500	-62.28	8.75	-53.53	-47.00	-6.53	peak

**Remark:**

1. Corr. = Antenna Factor (dB) + Cable Loss (dB)
2. Margin (dB) = Peak(dBm) - Limit (dBm)
3. The tests evaluated 1~12.75GHz, Test with highpass filter (Pass Frequency: 2.8-18G).
4. No report for the emission which below the prescribed limit.



Test Voltage:	DC 5V
Ant. Pol.	Horizontal
Test Mode:	RX Mode (869.9MHz)
Remark:	Only showed test data of the worst mode.

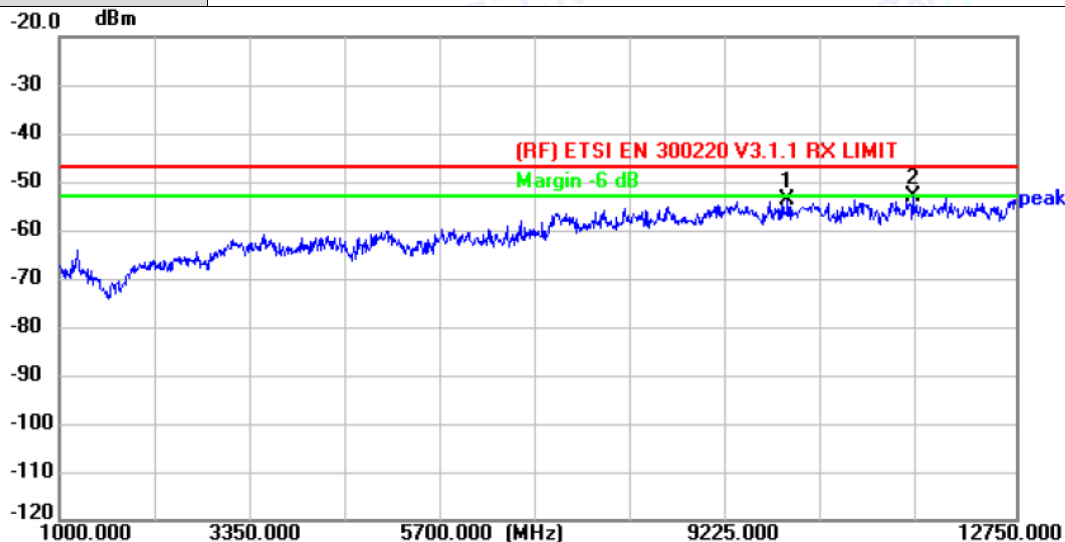

Temperature: 24.5 °C

Humidity: 51 %

No.	Frequency (MHz)	Reading (dBm)	Factor (dB)	Level (dBm)	Limit (dBm)	Margin (dB)	Detector
1	9941.7500	-62.01	8.16	-53.85	-47.00	-6.85	peak
2 *	11481.0000	-63.57	10.45	-53.12	-47.00	-6.12	peak

**Remark:**

1. Corr. = Antenna Factor (dB) + Cable Loss (dB)
2. Margin (dB) = Peak(dBm) - Limit (dBm)
3. The tests evaluated 1~12.75GHz, Test with highpass filter (Pass Frequency: 2.8-18G).
4. No report for the emission which below the prescribed limit.



Test Voltage:	DC 5V
Ant. Pol.	Vertical
Test Mode:	RX Mode (869.9MHz)
Remark:	Only showed test data of the worst mode.

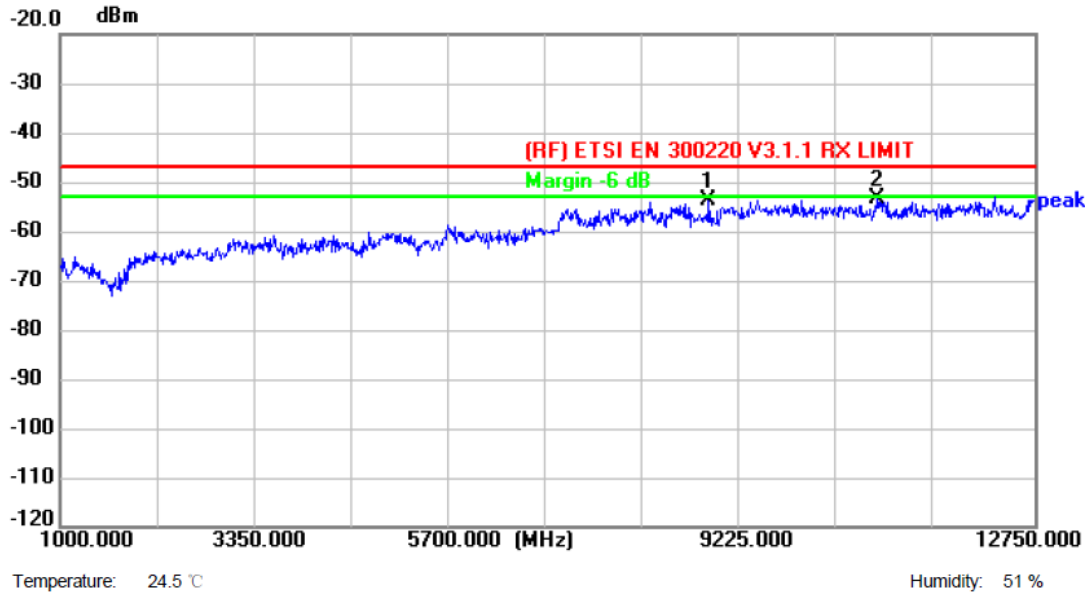

No.	Frequency (MHz)	Reading (dBm)	Factor (dB)	Level (dBm)	Limit (dBm)	Margin (dB)	Detector
1	8825.5000	-58.90	5.04	-53.86	-47.00	-6.86	peak
2 *	10858.2500	-63.05	9.70	-53.35	-47.00	-6.35	peak

**Remark:**

1. Corr. = Antenna Factor (dB) + Cable Loss (dB)
2. Margin (dB) = Peak(dBm) - Limit (dBm)
3. The tests evaluated 1~12.75GHz, Test with highpass filter (Pass Frequency: 2.8-18G).
4. No report for the emission which below the prescribed limit.



**Attachment B--TX Effective Radiated Power**

Test Mode :				TX Mode				
Test Conditions					ERP Power(dBm)			
					863.1MHz	866.5MHz	869.9MHz	
N nom	(°C)	25.0	V nom	(V)	5.0	10.250	10.150	9.970
Limits					25mW(13.98dBm)			
Result					PASS			



## Attachment C--Duty Cycle

Temperature :	25°C	Relative Humidity :	48%		
Pressure :	1020hPa	Test Voltage :	DC 5V		
Test Mode :	TX Mode(866.5MHz)				
<b>Blocking Signal Test(Category 2)</b>					
<b>Frequency</b>	<b>Transmit On Time (ms)</b>	<b>Periodic Time (ms)</b>	<b>Duty Cycle (%)</b>	<b>Limit (%)</b>	<b>Result</b>
866.5MHz	165	150000	0.11	≤1%	Pass
Transmit On Time=165ms Duty Cycle=ON/Periodic Time					



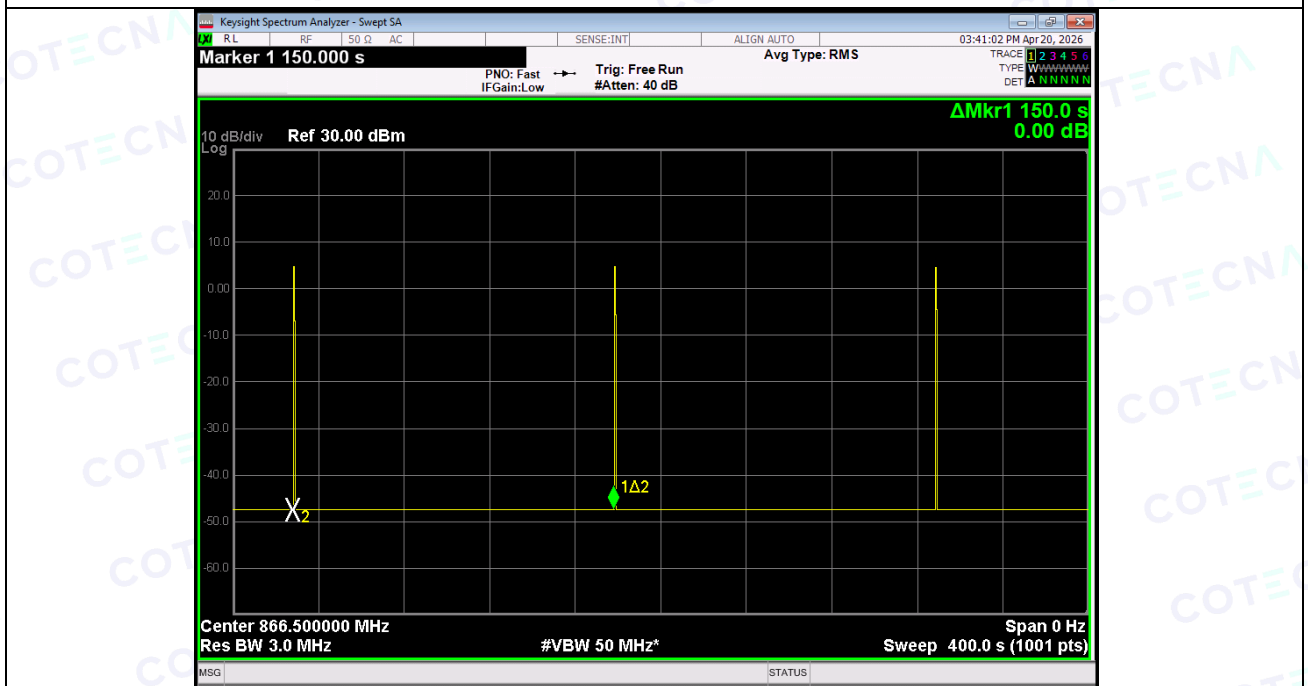
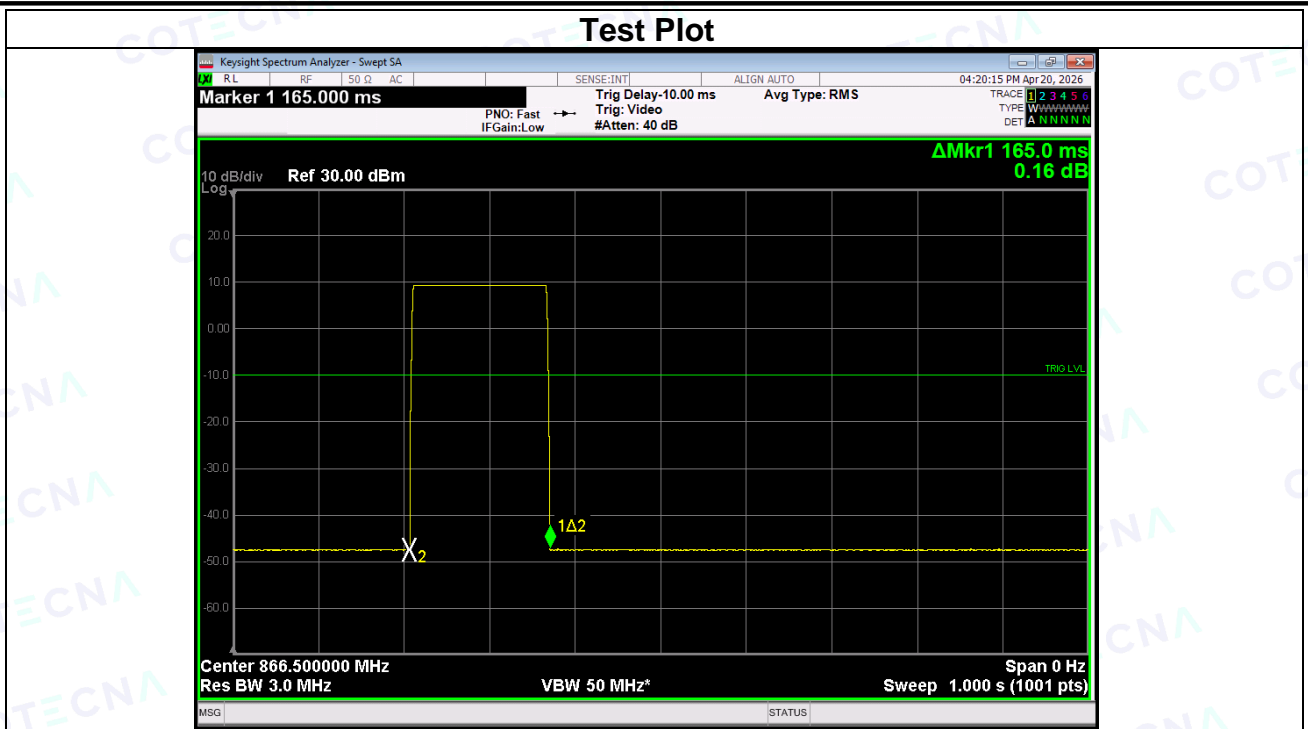

## Attachment D--TX Occupied Bandwidth

Modulated Signal Test			
Centre Frequency (MHz)	Occupied Channel Bandwidth (KHz)	Maximum Occupied Bandwidth (KHz)	Result
863.1	126.63	/	Pass
866.5	126.83	/	Pass
869.9	126.35	/	Pass

<p>Center Freq: 863.100000 MHz #Res BW: 3 kHz #VBW: 10 kHz Span: 250 kHz Sweep: 34.07 ms</p> <p>Occupied Bandwidth: 126.63 kHz Total Power: 20.5 dBm Transmit Freq Error: 226 Hz % of OBW Power: 99.00 % x dB Bandwidth: 154.1 kHz x dB: -26.00 dB</p>
<p>Center Freq: 866.500000 MHz #Res BW: 3 kHz #VBW: 10 kHz Span: 250 kHz Sweep: 34.07 ms</p> <p>Occupied Bandwidth: 126.83 kHz Total Power: 20.4 dBm Transmit Freq Error: 62 Hz % of OBW Power: 99.00 % x dB Bandwidth: 158.1 kHz x dB: -26.00 dB</p>
<p>Center Freq: 869.900000 MHz #Res BW: 3 kHz #VBW: 10 kHz Span: 250 kHz Sweep: 34.07 ms</p> <p>Occupied Bandwidth: 126.35 kHz Total Power: 20.8 dBm Transmit Freq Error: 240 Hz % of OBW Power: 99.00 % x dB Bandwidth: 152.9 kHz x dB: -26.00 dB</p>

Remark: the plot only show the worst case.



# Attachment E--TX Out of Band Emissions

**Test Mode:** TX Mode 863.1MHz

**Note:** All test modes were carried out for all operation modes under normal and extreme test conditions, the worst test data(TN,TV) is record in the report.

## Operating Channel with reference BW

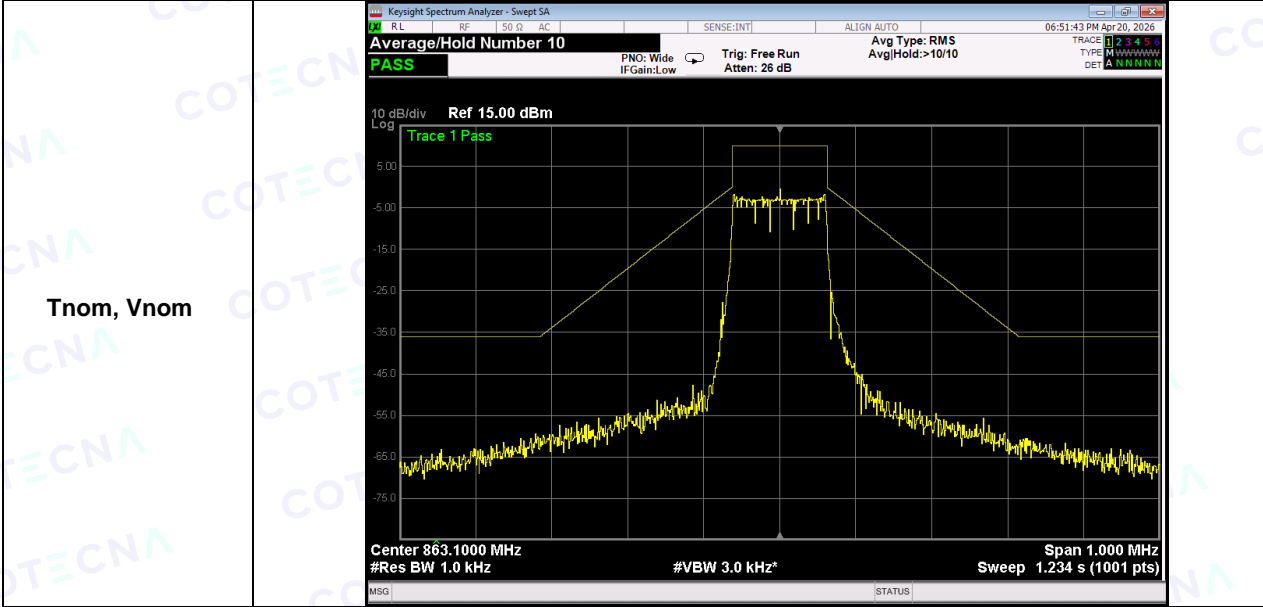

## Operational Frequency Band with reference BW

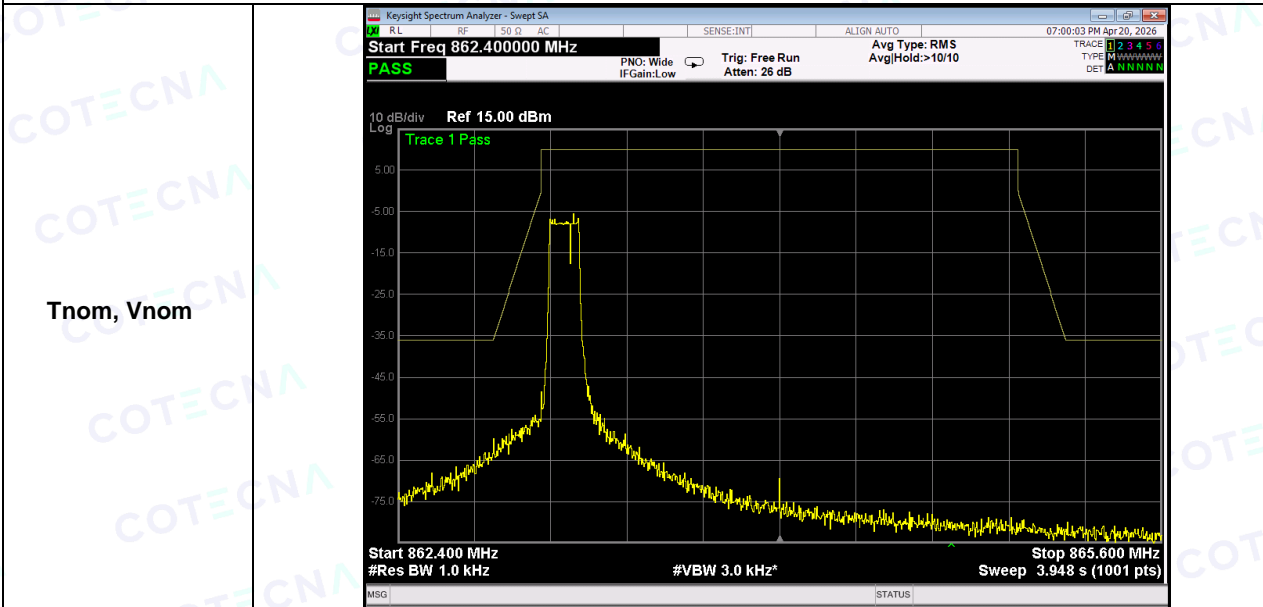

**Test Mode:** TX Mode 866.5MHz

**Note:** All test modes were carried out for all operation modes under normal and extreme test conditions, the worst test data(TN,TV) is record in the report.

**Operating Channel with reference BW**

Tnom, Vnom

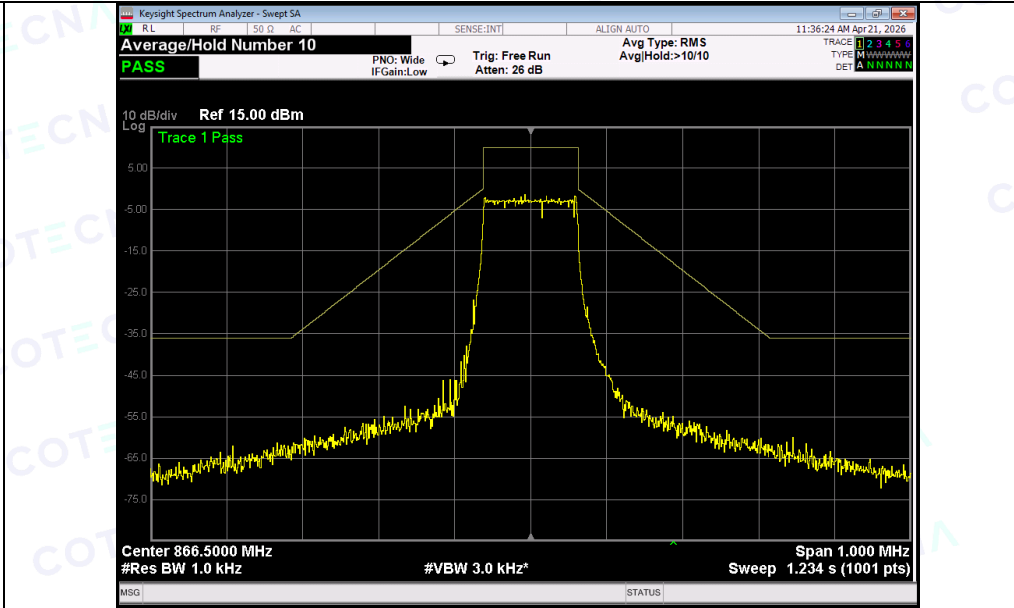

**Operational Frequency Band with reference BW**

Tnom, Vnom

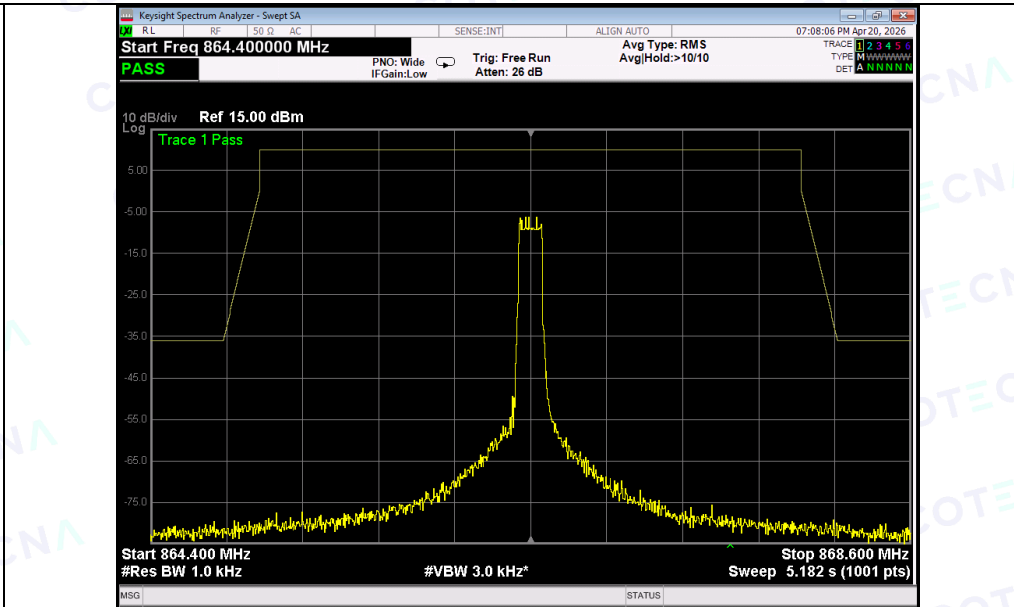

**Test Mode:** TX Mode 869.9MHz

**Note:** All test modes were carried out for all operation modes under normal and extreme test conditions, the worst test data(TN,TV) is record in the report.

**Operating Channel with reference BW**

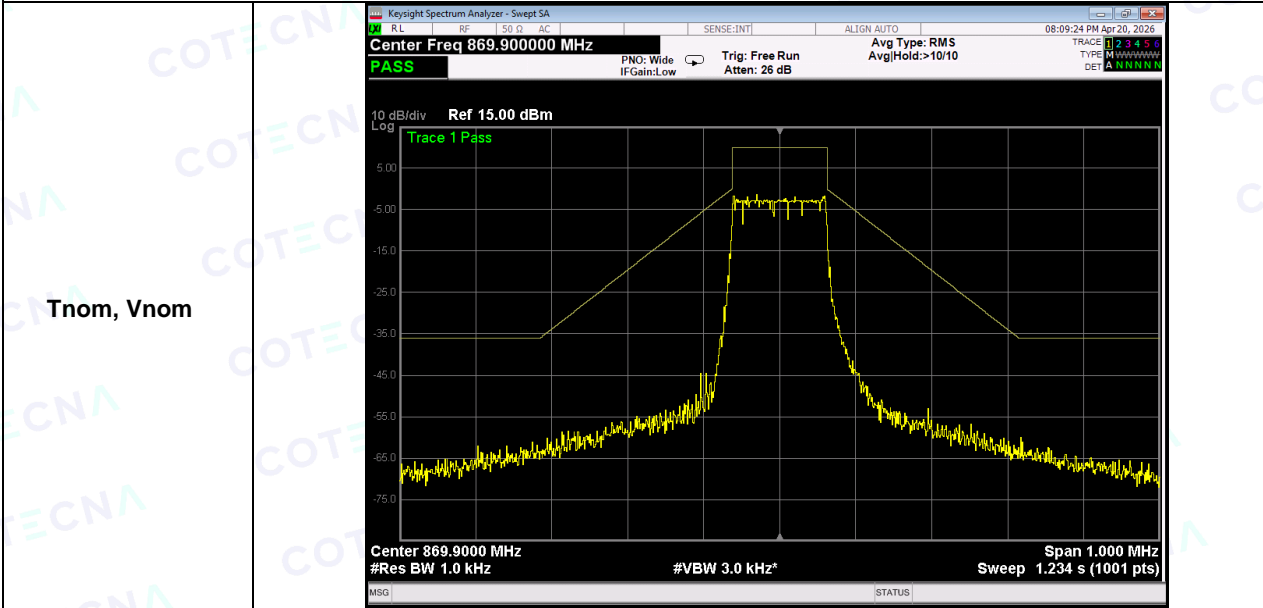

**Operational Frequency Band with reference BW**

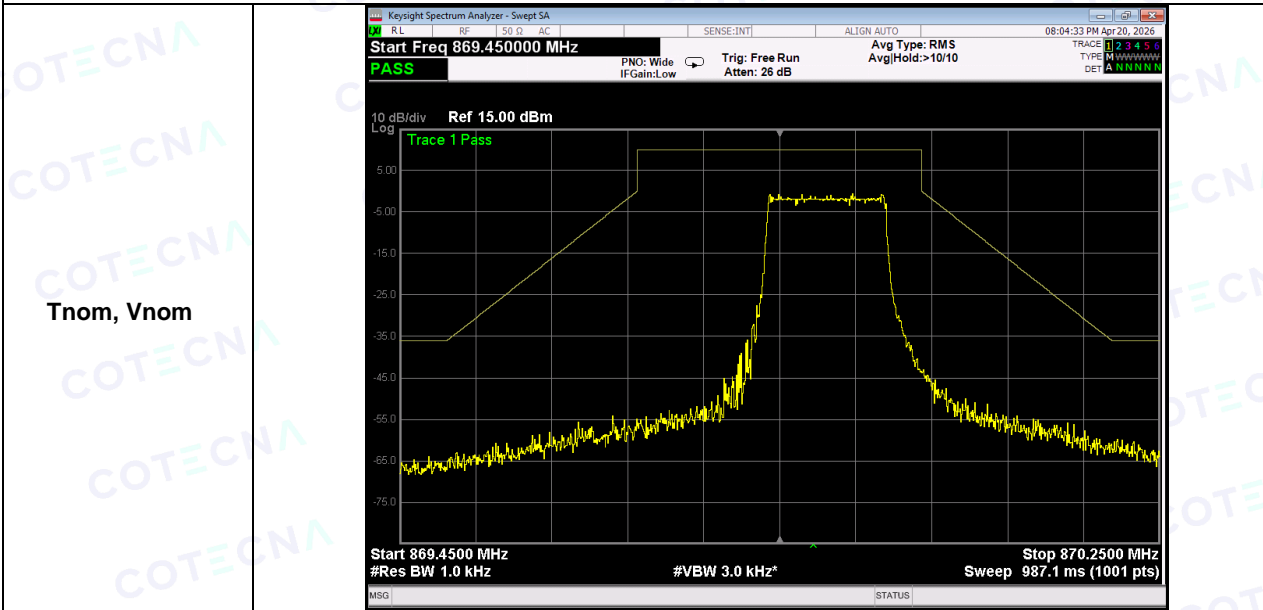

## Attachment F--Transient Power

Test Mode	Antenna	Frequency[MHz]	Freq. [MHz]	Level[dBm]	Limit[dBm]	Verdict
SRD	Ant1	863.1	861.89	-60.68	-27	PASS
SRD	Ant1	863.1	862.69	-48.02	-27	PASS
SRD	Ant1	863.1	863.08	-9.73	0	PASS
SRD	Ant1	863.1	863.087	-8.84	0	PASS
SRD	Ant1	863.1	863.113	-11.49	0	PASS
SRD	Ant1	863.1	863.12	-11.87	0	PASS
SRD	Ant1	863.1	863.51	-47.12	-27	PASS
SRD	Ant1	863.1	864.31	-60.02	-27	PASS
SRD	Ant1	866.5	865.29	-63.06	-27	PASS
SRD	Ant1	866.5	866.09	-48.07	-27	PASS
SRD	Ant1	866.5	866.48	-10.76	0	PASS
SRD	Ant1	866.5	866.487	-7.38	0	PASS
SRD	Ant1	866.5	866.513	-12.66	0	PASS
SRD	Ant1	866.5	866.52	-12.46	0	PASS
SRD	Ant1	866.5	866.91	-49.60	-27	PASS
SRD	Ant1	866.5	867.71	-63.92	-27	PASS
SRD	Ant1	869.6	868.39	-65.00	-27	PASS
SRD	Ant1	869.6	869.19	-50.46	-27	PASS
SRD	Ant1	869.6	869.58	-8.14	0	PASS
SRD	Ant1	869.6	869.587	-8.18	0	PASS
SRD	Ant1	869.6	869.613	-12.93	0	PASS
SRD	Ant1	869.6	869.62	-12.28	0	PASS
SRD	Ant1	869.6	870.01	-47.90	-27	PASS
SRD	Ant1	869.6	870.81	-64.62	-27	PASS



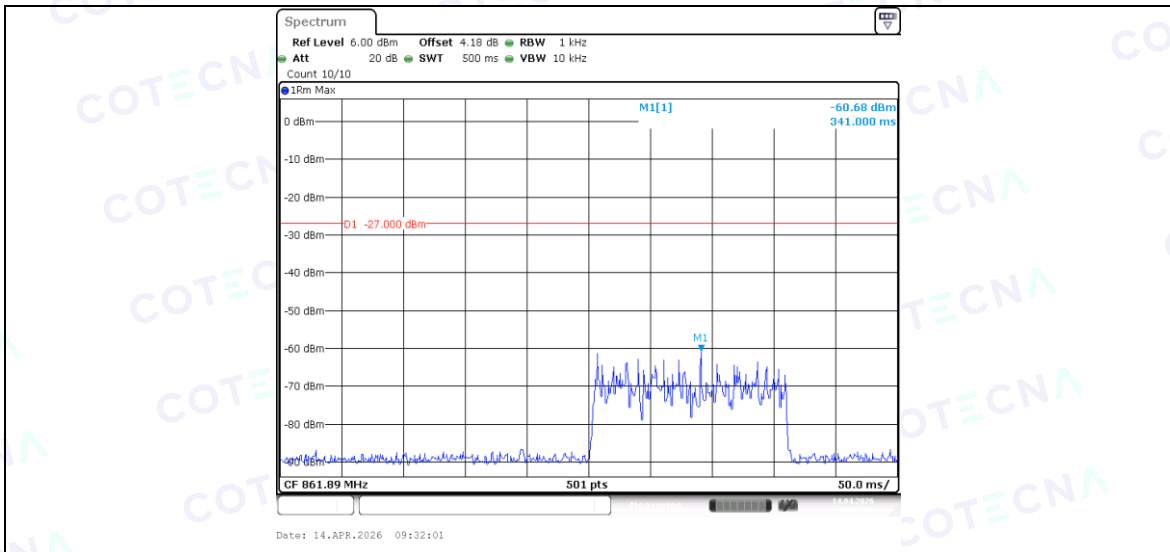

SRD-Ant1-863.1-861.89--1200-PASS

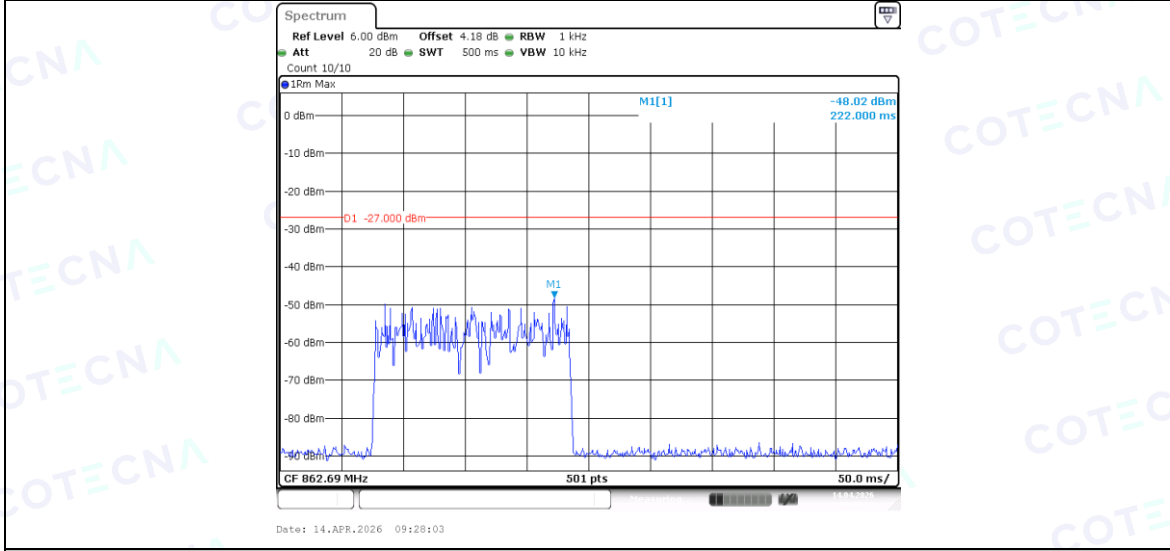

SRD-Ant1-863.1-862.69--400-PASS

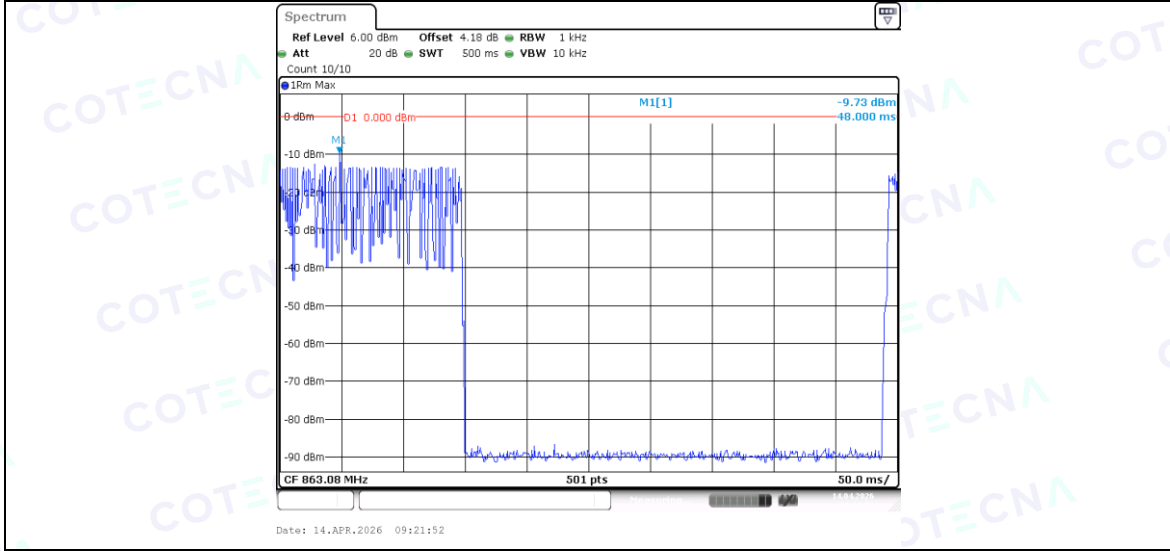

SRD-Ant1-863.1-863.08--20-PASS



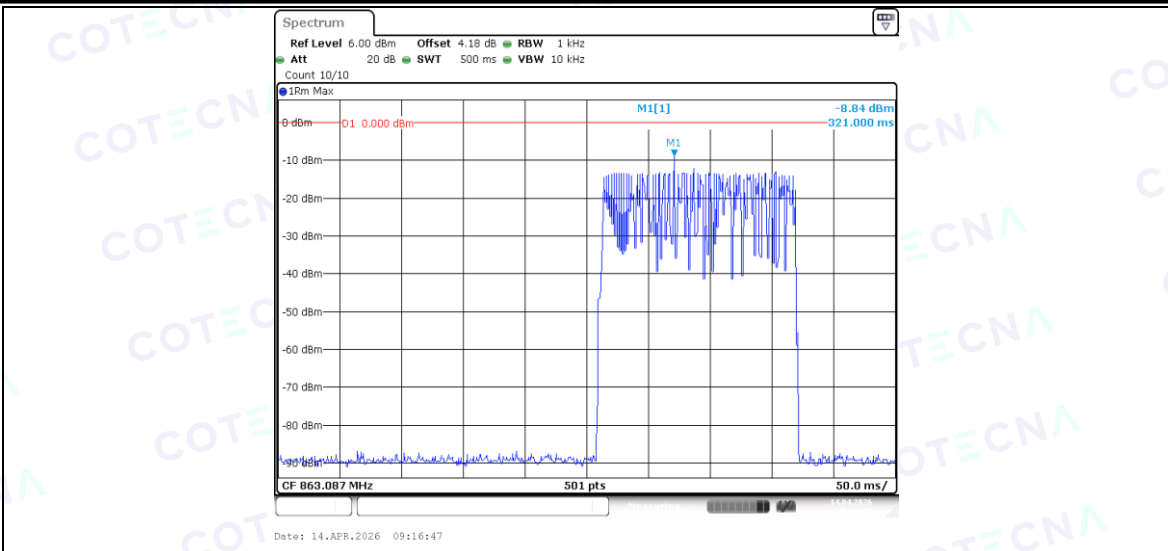

SRD-Ant1-863.1-863.087--3-PASS

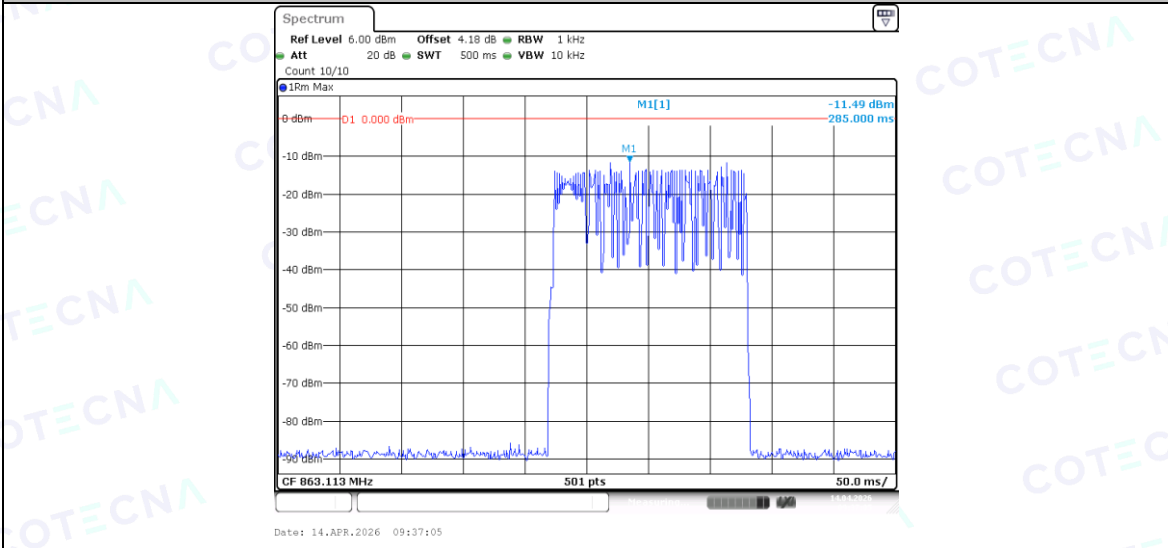

SRD-Ant1-863.1-863.113-3-PASS

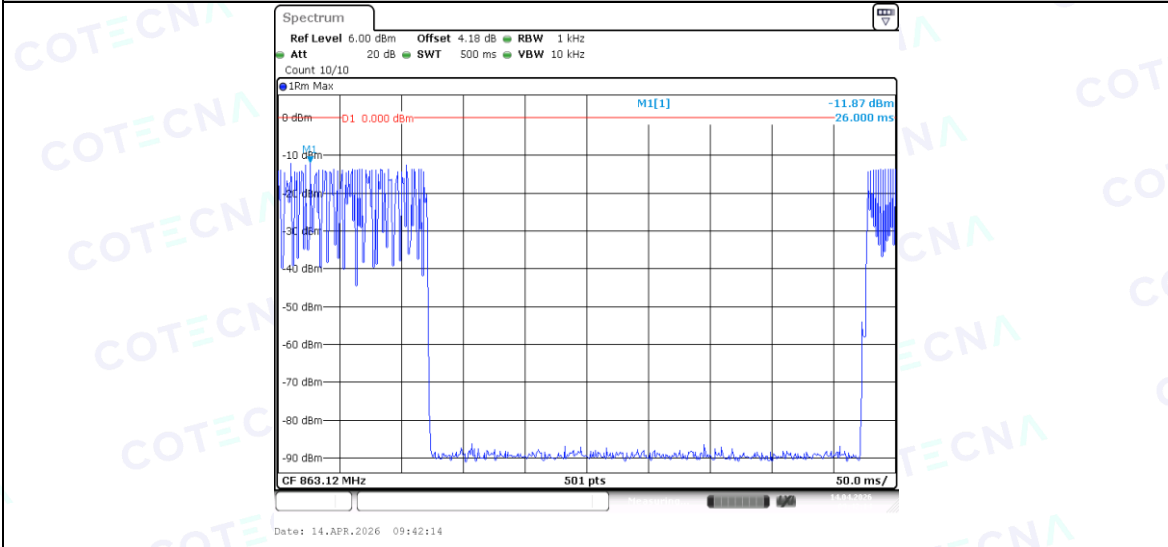

SRD-Ant1-863.1-863.12-20-PASS



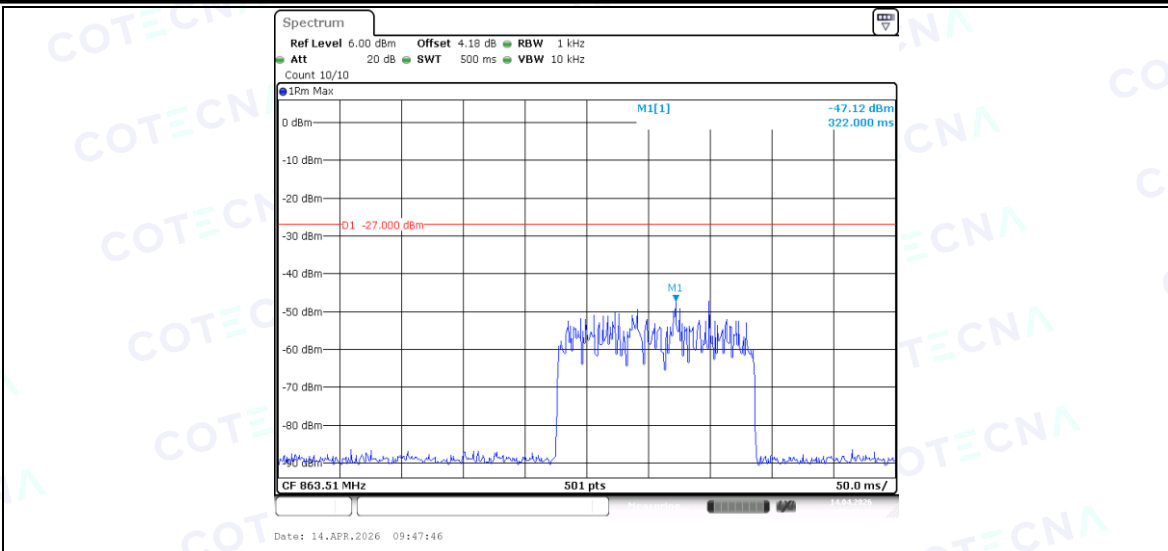

SRD-Ant1-863.1-863.51-400-PASS

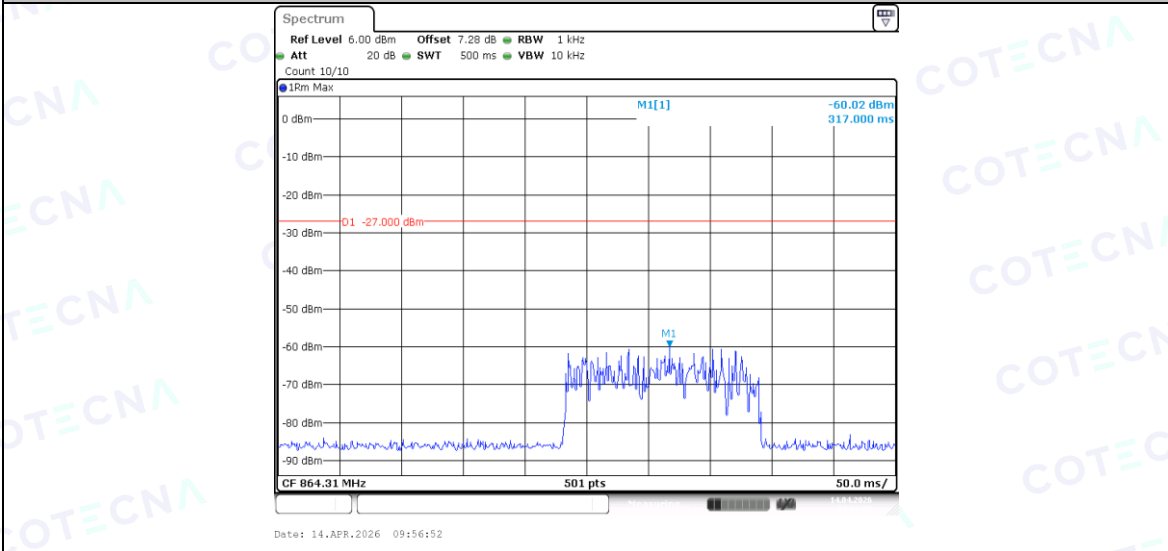

SRD-Ant1-863.1-864.31-1200-PASS

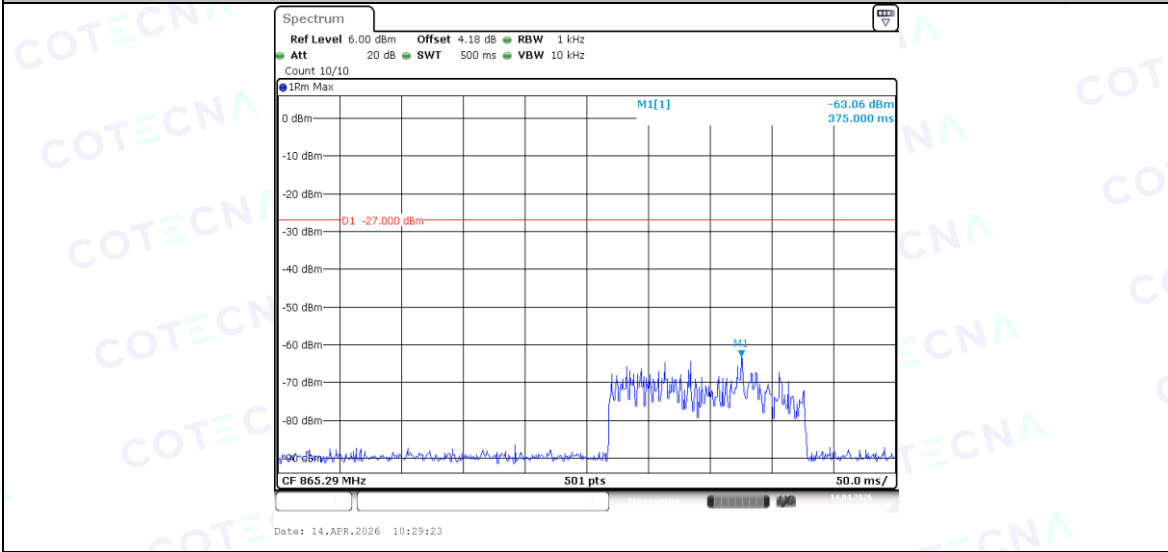

SRD-Ant1-866.5-866.29--1200-PASS



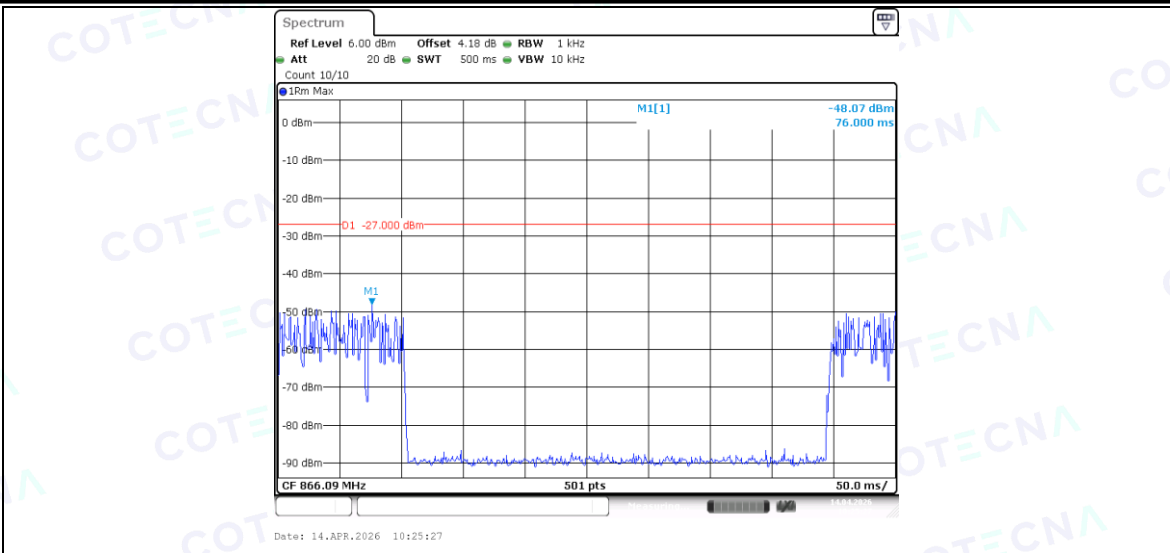

SRD-Ant1-866.5-866.09--400-PASS

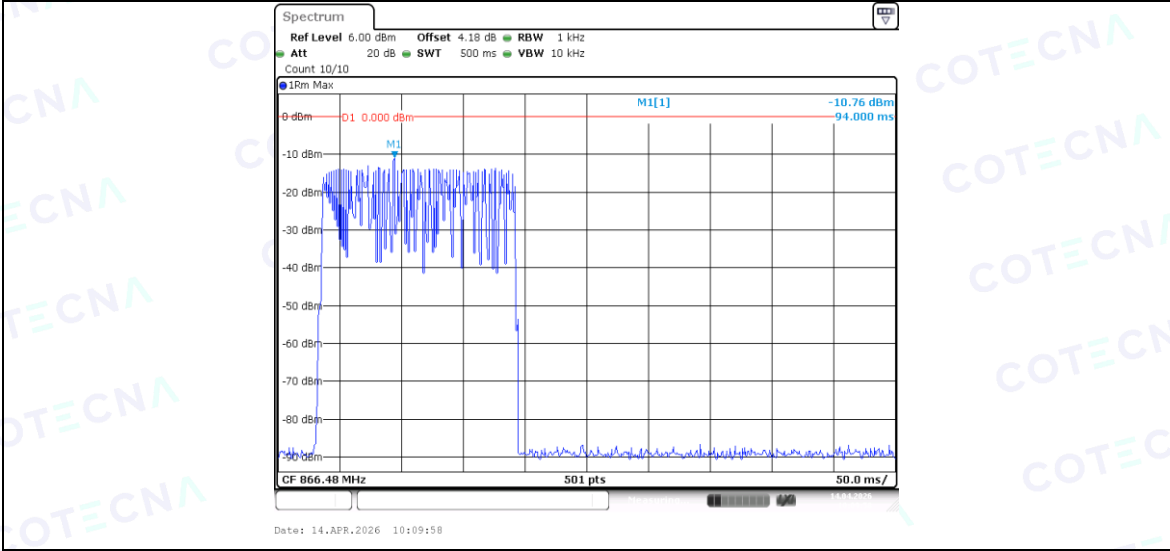

SRD-Ant1-866.5-866.48--20-PASS

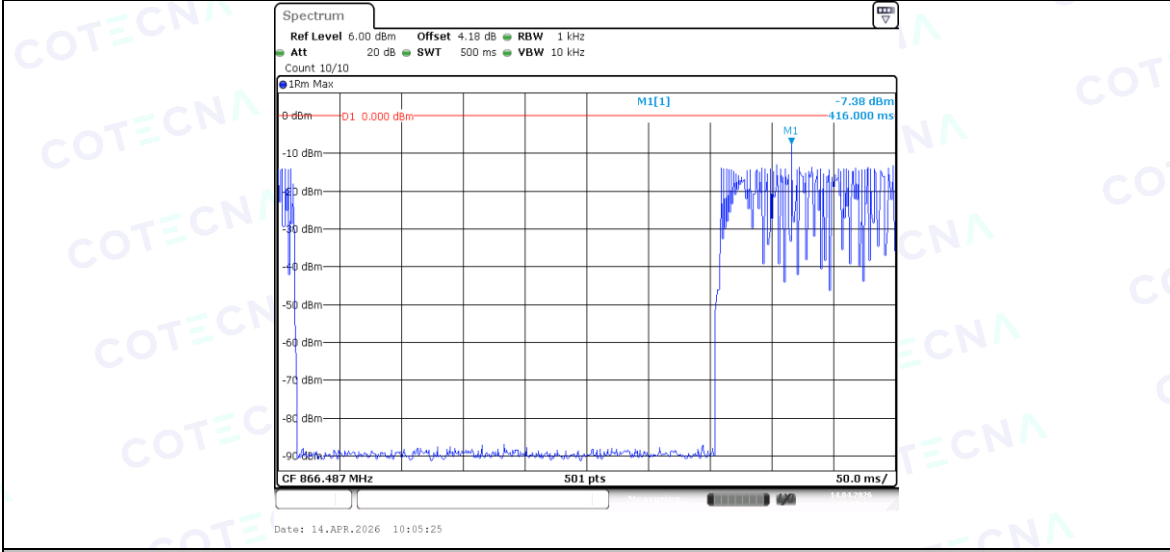

SRD-Ant1-866.5-866.487--3-PASS



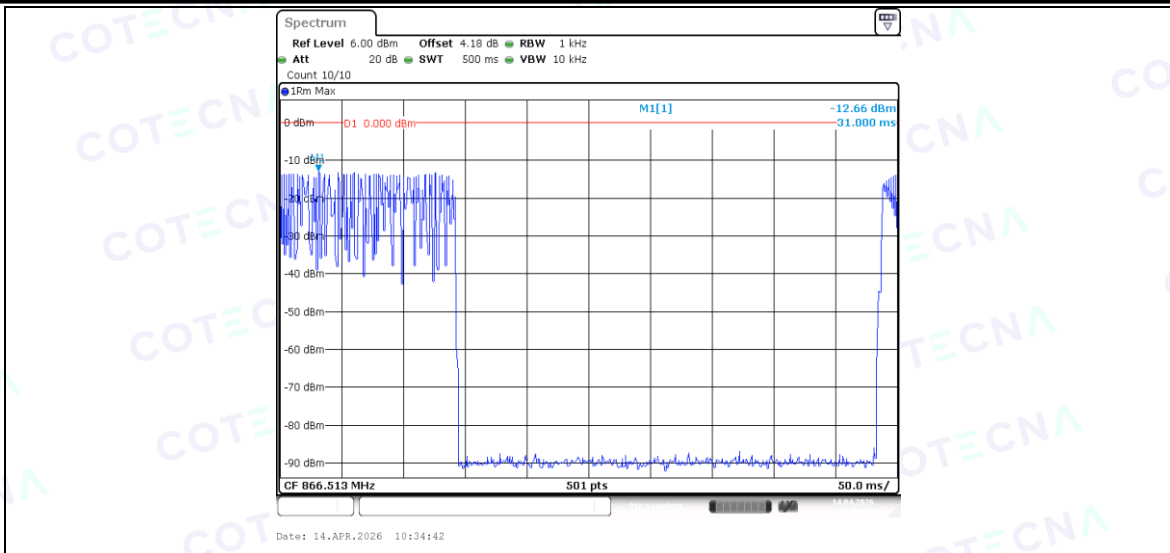

SRD-Ant1-866.5-866.513-3-PASS

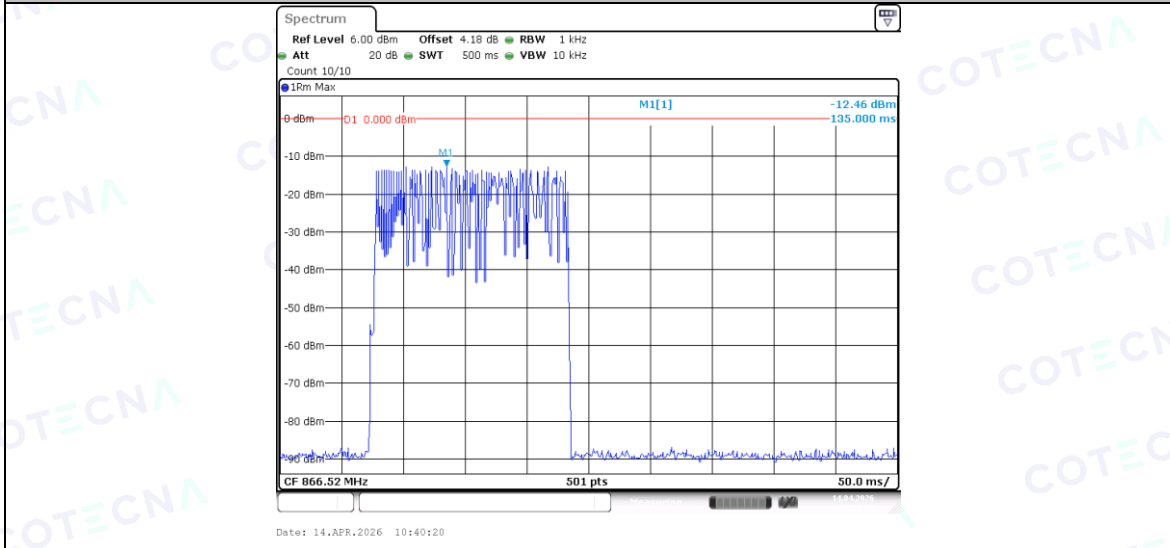

SRD-Ant1-866.5-866.52-20-PASS

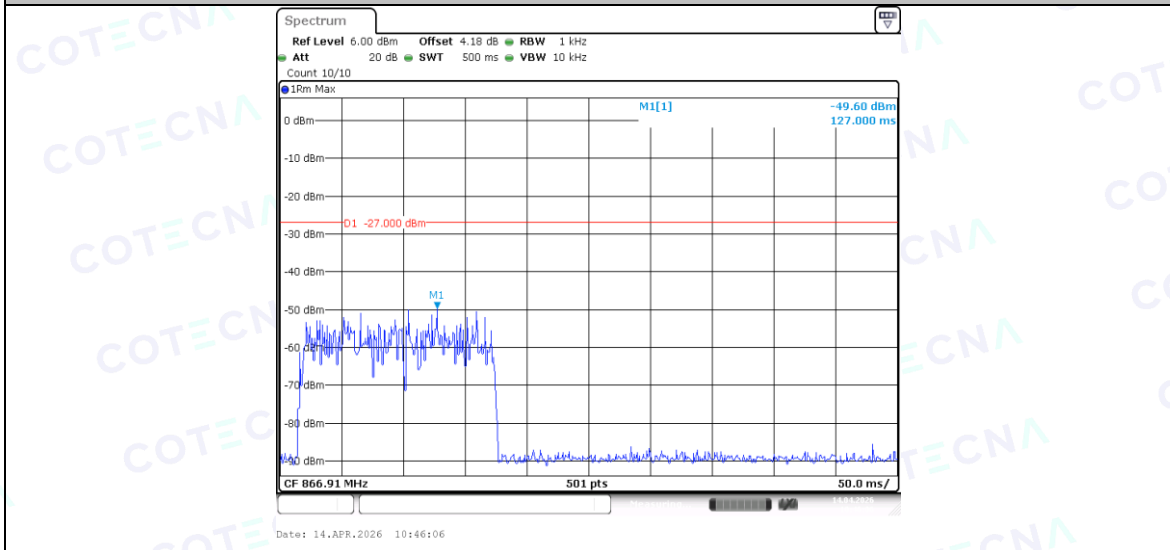

SRD-Ant1-866.5-866.91-400-PASS



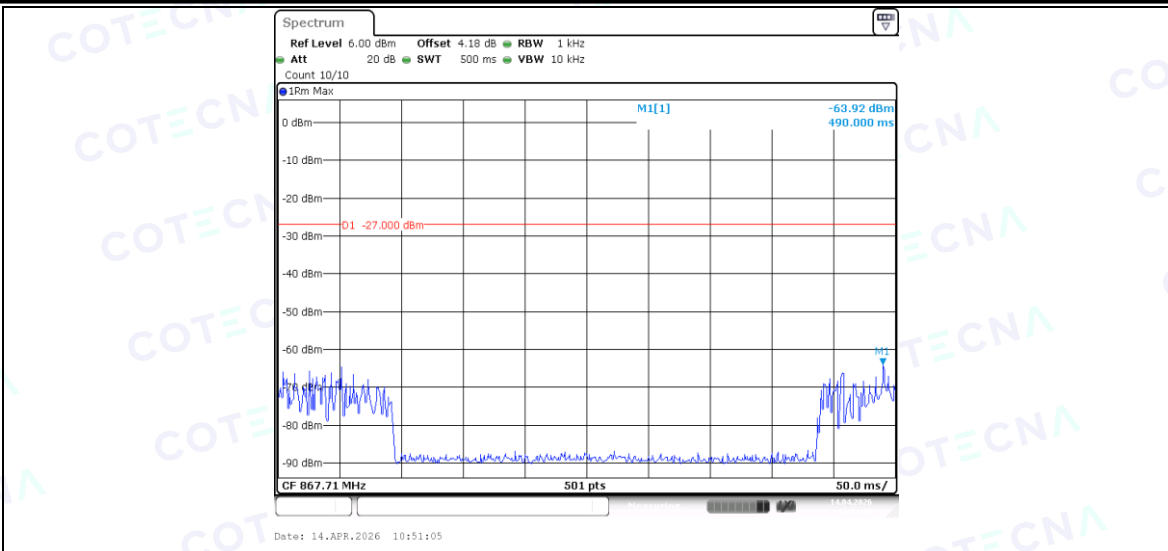

SRD-Ant1-866.5-867.71-1200-PASS

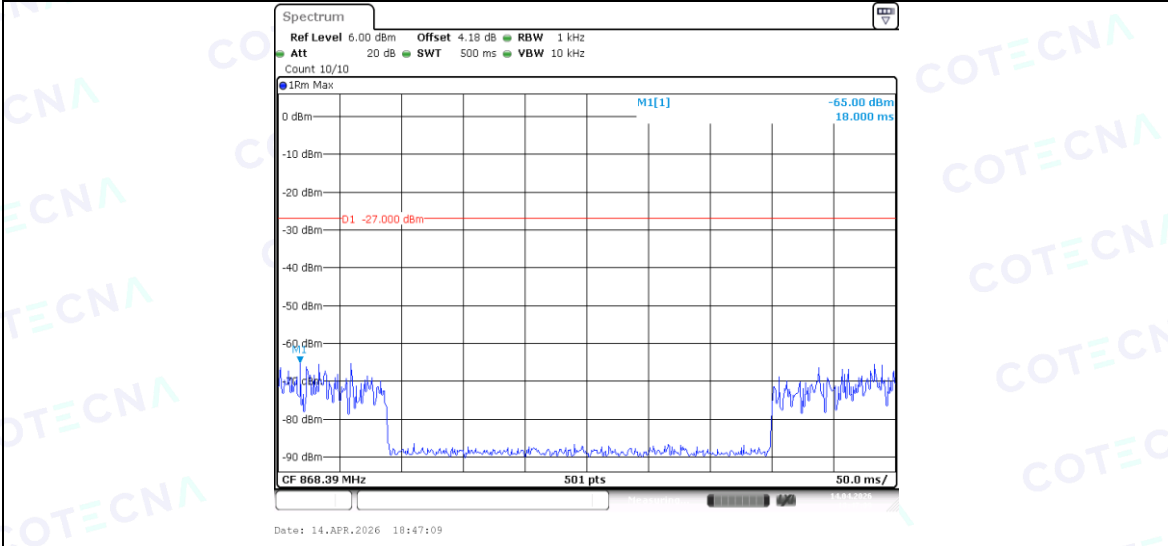

SRD-Ant1-869.6-868.39--1200-PASS

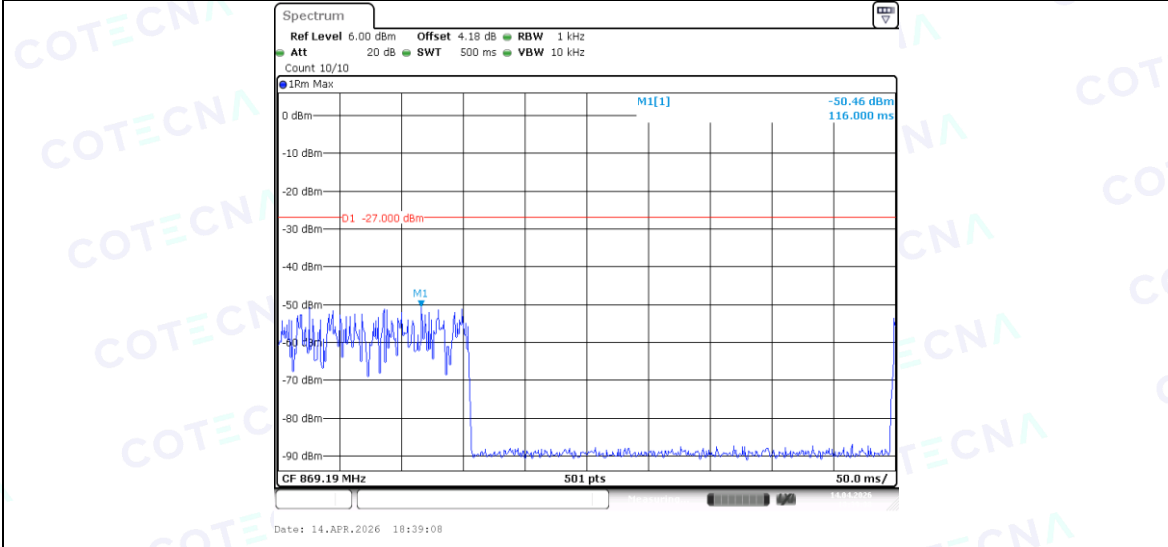

SRD-Ant1-869.6-869.19--400-PASS



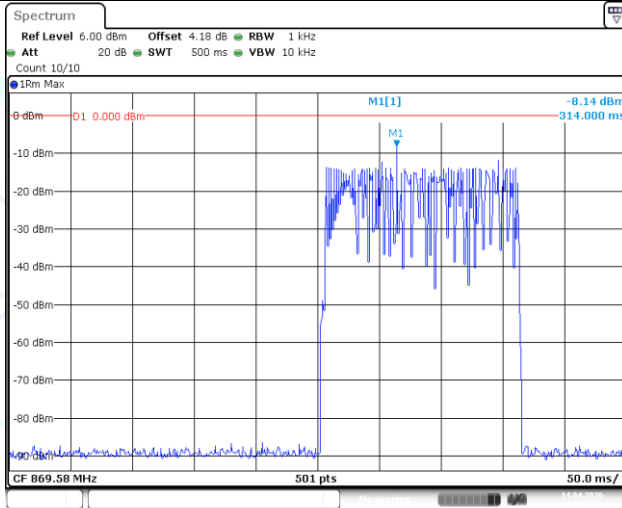

Date: 14.APR.2026 10:31:29

SRD-Ant1-869.6-869.58--20-PASS

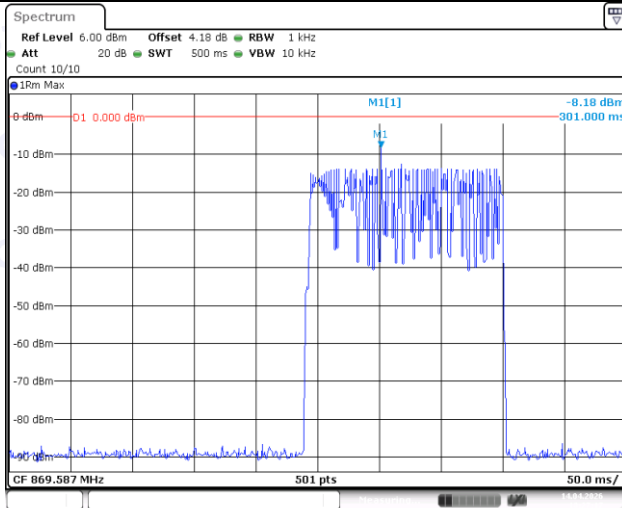

Date: 14.APR.2026 10:27:17

SRD-Ant1-869.6-869.587--3-PASS

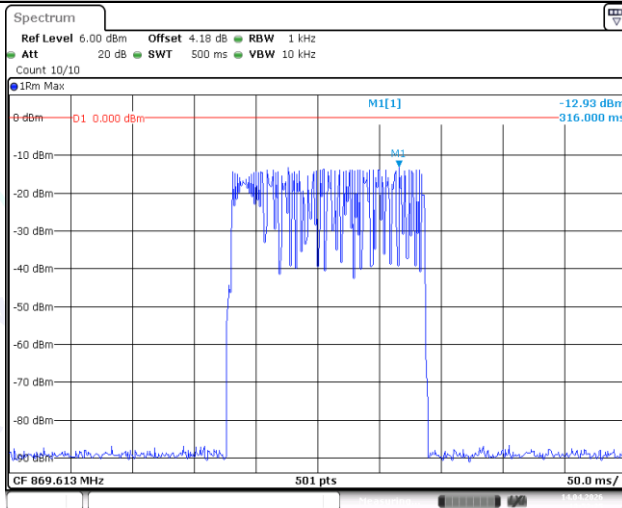

Date: 14.APR.2026 10:52:25

SRD-Ant1-869.6-869.613-3-PASS



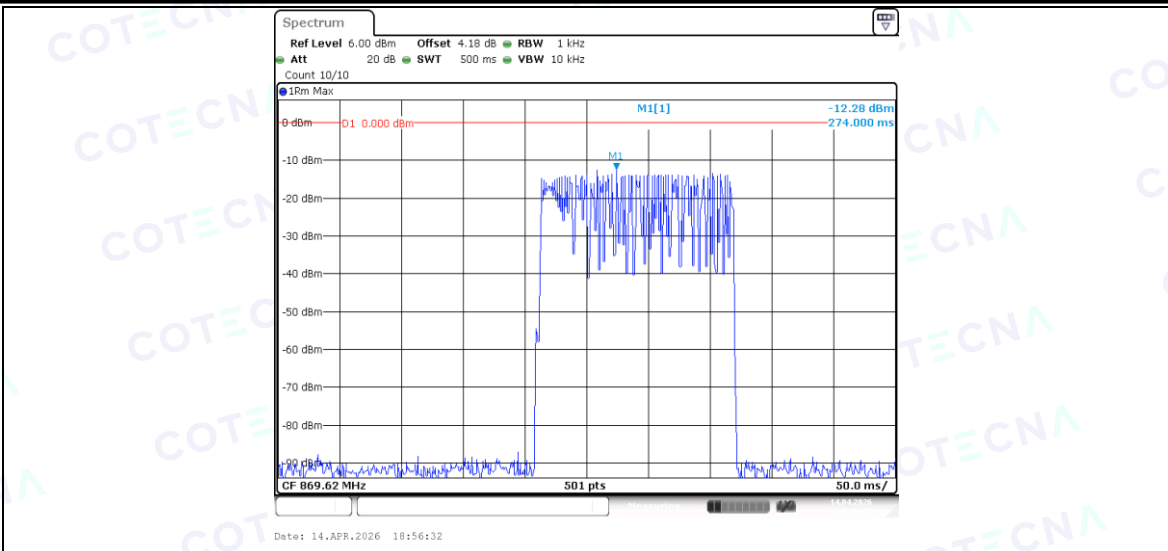

SRD-Ant1-869.6-869.62-20-PASS

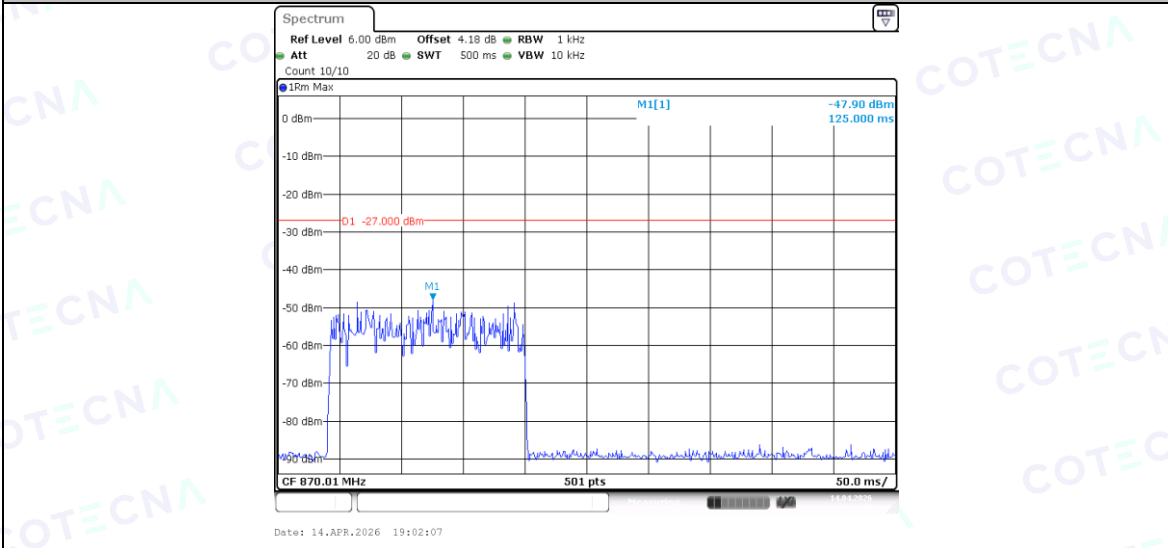

SRD-Ant1-869.6-870.01-400-PASS

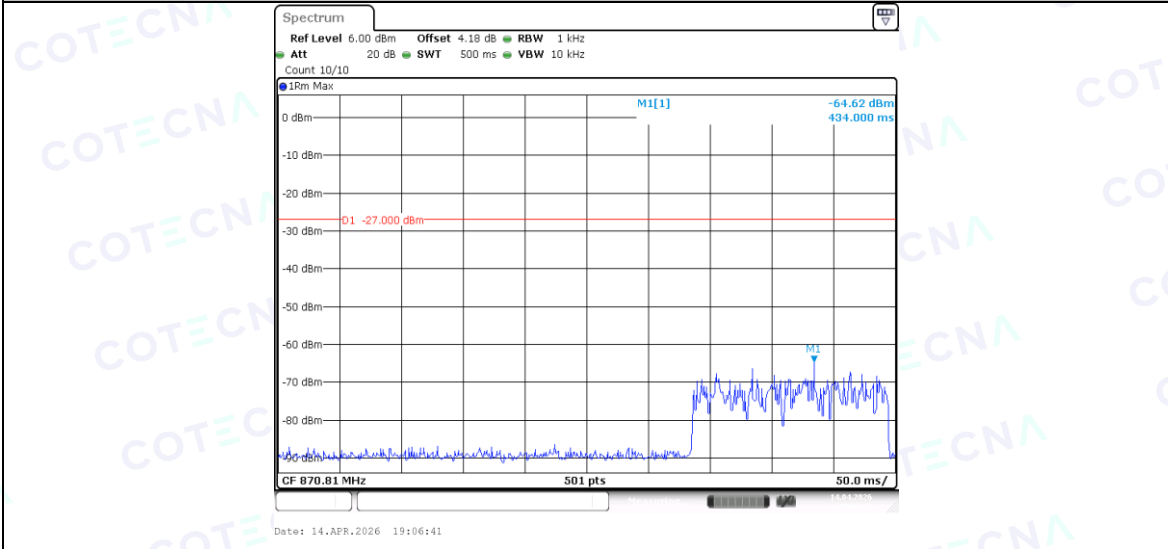

SRD-Ant1-869.6-870.81-1200-PASS



## Attachment G--Blocking

<b>Temperature:</b>	25°C	<b>Relative Humidity:</b>	46%
<b>Pressure:</b>	1020hPa	<b>Test Voltage:</b>	DC 5V
<b>Test Mode:</b>	Receive Mode (863.1MHz)		
Blocking Signal Test (Category 2)			
Frequency offset	Blocking Signal B-A (dB)	Limit (dB)	Result
+2 MHz	-59.02	≥-69	Pass
-2 MHz	-60.24	≥-69	Pass
+10 MHz	-33.45	≥-44	Pass
-10 MHz	-33.22	≥-44	Pass
+46 MHz	-27.32	≥-44	Pass
-46 MHz	-22.74	≥-44	Pass

<b>Temperature:</b>	25°C	<b>Relative Humidity:</b>	46%
<b>Pressure:</b>	1020hPa	<b>Test Voltage:</b>	DC 5V
<b>Test Mode:</b>	Receive Mode (866.5MHz)		
Blocking Signal Test (Category 2)			
Frequency offset	Blocking Signal B-A (dB)	Limit (dB)	Result
+2 MHz	-61.26	≥-69	Pass
-2 MHz	-63.68	≥-69	Pass
+10 MHz	-34.89	≥-44	Pass
-10 MHz	-33.54	≥-44	Pass
+46 MHz	-31.14	≥-44	Pass
-46 MHz	-26.25	≥-44	Pass



<b>Temperature:</b>	25°C	<b>Relative Humidity:</b>	46%
<b>Pressure :</b>	1020hPa	<b>Test Voltage :</b>	DC 5V
<b>Test Mode :</b>	Receive Mode (869.9MHz)		
Blocking Signal Test(Category 2)			
Frequency offset	Blocking Signal B-A (dB)	Limit (dB)	Result
+2 MHz	-60.10	≥-69	Pass
-2 MHz	-62.98	≥-69	Pass
+10 MHz	-31.74	≥-44	Pass
-10 MHz	-32.35	≥-44	Pass
+46 MHz	-24.21	≥-44	Pass
-46 MHz	-22.65	≥-44	Pass

-----END OF THE REPORT-----

